



# VisionPass

## Installation guide





---

# Warning

COPYRIGHT © 2020 Idemia. All rights reserved.

Reproduction in whole or in part in any form or medium without the express written permission of Idemia is prohibited. The trademarks identified herein are the trademarks of registered trademarks of Idemia, or other third party.

This legend is applicable to all pages of this document.

Information in this document is subject to change without notice and do not represent a commitment on the part of Idemia.

This manual makes reference to names and products that are trademarks of their respective owners.

---

# Revision history

Version	Date	Reference	Description
<b>01</b>	April 2020	2019_2000045728	Document creation

---

# Table of content

---

<b>1 / Introduction</b>	<b>7</b>
1.1 > VisionPass terminal	8
1.2 > Scope of the document	9
1.3 > Safety Instructions	10
1.4 > Wiring Recommendations	11
1.5 > Regulatory, safety and Environmental notices	12
1.5.1 > European Union (CE) regulatory notices	12
1.5.2 > USA (FCC) regulatory notices	13
1.5.3 > Canada (IC) regulatory notices	14
1.6 > Others recommendations	16
1.7 > Recommendations for terminal implementation	17

---

<b>2 / General description</b>	<b>20</b>
2.1 > Box opening	21
2.2 > Components of the initial package	22
2.3 > Terminal's front view description	23
2.4 > Terminal's rear view description	24
2.5 > VisionPass Technical Characteristics	25

---

<b>3 / Installation procedure</b>	<b>28</b>
3.1 > Before proceeding to the installation	29
3.2 > Installation	30
3.3 > Step by step procedure	31
3.3.1 > Drill the mounting holes	32
3.3.2 > Make the connections	33
3.3.3 > Attach the base plate on the wall	36
3.3.4 > Attach the device on the base plate	37
3.3.5 > Connect the connector assembly on the device	38
3.3.6 > Close the device on the base plate	39

---

<b>4 / Electrical interface</b>	<b>42</b>
4.1 > Wiring overview	43
4.2 > Power Supply	44

4.3 > Output Relay	45
4.4 > Tamper Switch	46
4.5 > Wiegand wiring	47
4.6 > Wiegand output	48
4.7 > Serial port wiring	50
4.8 > GPIO wiring	52
4.9 > Ethernet connection	53
4.10 > Internal USB connection	54
4.11 > Wi-Fi™ dongle installation	56
<hr/>	
<b>5 / User interface</b>	<b>58</b>
5.1 > Modes for controlling access rights	59
5.1.1 > Introduction	59
5.1.2 > Identification mode	59
5.1.3 > Authentication (verification) mode	59
5.1.4 > Multi-factor mode	60
5.1.5 > Proxy mode	60
5.1.6 > External database mode (also called polling mode)	61
5.1.7 > Anti-tamper / anti-pulling switches	61
<hr/>	
<b>6 / Accessories, Software Licenses and PC Applications</b>	<b>62</b>
6.1 > Compatible Accessories, Licenses and Software	63
6.2 > Compatible PC applications	64
<hr/>	
<b>7 / Recommendations</b>	<b>65</b>
<hr/>	
<b>8 / Annex 1 : placement recommendations</b>	<b>68</b>
8.1 > Main principles	69
8.2 > Enrolment recommendations	70
<hr/>	
<b>9 / Annex 2 : Bibliography</b>	<b>71</b>
9.1 > How to get the latest versions of documents	72
9.2 > Documents about the MorphoWave Compact terminal	73
<hr/>	
<b>10 / Annex 3 : Support</b>	<b>74</b>
10.1 > Troubleshooting	75
10.2 > Technical Support and Hotline	75

---

# 1 / Introduction



## 1.1 > VisionPass terminal

To ensure the most effective use of your VisionPass terminal, we recommend that you read this Installation Guide completely.



## 1.2 > Scope of the document

This guide deals with the installation of VisionPass, which is made up of the following list of products:

VisionPass Marketing Name	Biometrics	Contactless smartcard reader			Water Resistant	Regulatory Model Number (*)
		iCLASS®	MIFARE® DESFire® NFC	Prox®		
VisionPass MD	✓		✓		✓	MPH-AC006A
VisionPass MDPI	✓	✓	✓	✓	✓	MPH-AC006B

(\*) The Regulatory Model Number is the main product identifier in the regulatory documentation and test reports associated to the product

## 1.3 > Safety Instructions

 means Direct Current (DC)

The installation of this product should be made by a qualified service Person and should comply with all local regulations.

It is strongly recommended to use a class II power supply at 12V-24V and 3 A min (at 12V) in conformity with Safety Electrical Low Voltage (SELV). The AC power supply cable length should not exceed 10 meters.

This system must be installed in accordance with the National Electrical Code (NFPA 70), and the local authority having jurisdiction.

This product is intended to be installed with a power supply complying with IEC60950-1 or IEC62368-1, in accordance with the NEC Class 2 requirements; or supplied by a listed IEC60950-1 or IEC62368-1 external Power Unit marked Class 2, Limited Power source, or LPS and rated 12VDC, 3 A minimum or 24VDC, 1.5 A minimum.

In case of building to building connection it is recommended to connect 0V to ground. Ground cable must be connected with the terminal block Power Ground.

Note that all connections of the VisionPass terminal described hereafter are of SELV (Safety Electrical Low Voltage) type.

This product is classified as Class 1 Laser Product according to IEC 60825-1 : 2014.

NB : duration of the pulse is 15ms every 66,67ms (15Hz) @ 940nm.

## 1.4 > Wiring Recommendations

Idemia recommends using a AWG16 gauge and 24V power supply.

The voltage specified is the one measured on the product block connector: 12V-24V (-15% / +10%).

The voltage drop due to the cable shall be taken into account. The following table shows the maximum distance between power supply and one (1) unique device, depending on cable gauge and power supply rating:

Gauge AWG	Section (mm <sup>2</sup> )	Maximum distance (meters) vs power source rating			
		12 V +/- 10% 3,6 A	12 V +/- 5% 3,5 A	24 V +/- 10% 2 A	24 V +/- 10% 3 A
<b>16</b>	1.31	6 m	12 m	68 m	121 m
<b>18</b>	0.82	4 m	8 m	43 m	76 m
<b>20</b>	0.52	2 m	5 m	27 m	48 m
<b>22</b>	0.32	1 m	3 m	16 m	30 m

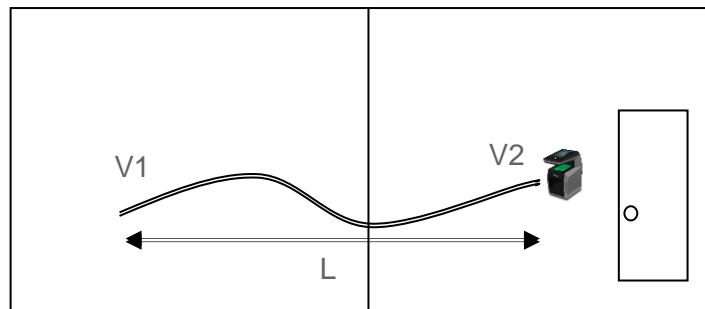

**Figure: Power supply voltage dropout considerations**

Drop voltage = loss of power due to wire resistance and its length:  $V2 = V1 - \text{Drop voltage}$

**WARNING:** Under powering may cause memory and data corruption; over powering may cause hardware damage. Both of these situations will void the warranty

## 1.5 > Regulatory, safety and Environmental notices

### 1.5.1 > European Union (CE) regulatory notices

#### ***Declaration of Conformity***



Products bearing the CE marking comply with one or more of the following EU Directives as may be applicable:

Radio Equipment Directive (RED) 2014/53/UE

Ecodesign Directive 2009/125/EC

RoHS Directive 2011/65/EU and 2011/65/UE

Compliance with these directives is assessed using applicable European Harmonised Standards.

VisionPass terminals are intended to be used for professional application only (buildings, airport...).

The full Declaration of Conformity is available on demand to your reseller. Please, provide him the product model name or its Regulatory Model Number (Model on the label).

#### ***Products with wireless features (EMF)***

This product meets the provisions of the EU's Council recommendation 1999/519/EC on the limitation of the exposure of the general public to electromagnetic fields (0 Hz to 300 GHz).

## 1.5.2 > USA (FCC) regulatory notices



*This device complies with part 15 of the FCC Rules. Operation is subject to the following two conditions: (1) this device may not cause harmful interference, and (2) this device must accept any interference received, including interference that may cause undesired operation.*

*This device complies with FCC RF radiation exposure limits set forth for general population. This device must be installed to provide a separation distance of at least 20cm from all persons and must not be co-located or operating in conjunction with any other antenna or transmitter*

Changes or modifications not expressly approved by the party responsible for compliance could void the user's authority to operate the equipment.

Responsible Party:

**Idemia Identity & Security FRance**  
**2 place Samuel de Champlain**  
**92400 Courbevoie – France**

**NOTA :** *This equipment has been tested and found to comply with the limits for a Class B digital device, pursuant to Part 15 of the FCC Rules. These limits are designed to provide reasonable protection against harmful interference in a residential installation. This equipment generates, uses and can radiate radio frequency energy and, if not installed and used in accordance with the instructions, may cause harmful interference to radio communications. However, there is no guarantee that interference will not occur in a particular installation. If this equipment does cause harmful interference to radio or television reception, which can be determined by turning the equipment off and on, the user is encouraged to try to correct the interference by one of the following measures:*

Reorient or relocate the receiving antenna.

Increase the separation between the equipment and receiver.

Connect the equipment into an outlet on a circuit different from that to which the receiver is connected.

Consult the dealer or an experienced radio/TV technician for help.

Shielded cables must be used with this unit to ensure compliance with category B FCC restrictions.

MPH-AC006B product model includes a module tested under the FCC rules for a Modular Approval.

FCCID: JQ6-SE3210

### 1.5.3 > Canada (IC) regulatory notices

#### *WARNING TO USERS IN THE CANADA / ATTENTION POUR LES UTILISATEURS AU CANADA*

This device complies with Industry Canada license-exempt RSS standard(s). Operation is subject to the following two conditions: (1) this device may not cause interference, and (2) this device must accept any interference, including interference that may cause undesired operation of the device.

Under Industry Canada regulations, this radio transmitter may only operate using an antenna of a type and maximum (or lesser) gain approved for the transmitter by Industry Canada.

To reduce potential radio interference to other users, the antenna type and its gain should be so chosen that the equivalent isotropically radiated power (e.i.r.p.) is not more than that necessary for successful communication.

This device complies with Industry Canada RF radiation exposure limits set forth for general population. This device must be installed to provide a separation distance of at least 20cm from all persons and must not be co-located or operating in conjunction with any other antenna or transmitter.

Note : UL LLC has not verified this product for compliance in respect to Canadian standards.

MPH-AC006B product model includes a module compliant with limits set by Industry Canada

- IC: 2236B-SE3210

This device complies with Industry Canada's RNCs for unlicensed radio devices. Exploitation is permitted under the following two conditions:

- 1) The device must not cause interference.
- 2) The user of the device must accept any radio interference, even if the interference may compromise its operation.

In accordance with Industry Canada regulations, this radio transmitter may operate with a specific antenna and maximum gain (or lower) approved for the transmitter by Industry Canada. In order to reduce the risk of radio interference for other users, The type of antenna and its gain must be chosen so that the equivalent radiated isotropic power (p.i.r.e.) does not exceed the intensity necessary to establish satisfactory communication.

This device complies with industry canada's defined levels of RF exposure requirements. The device must be installed to offer a separation distance of at least 20cm with the user, and should not be installed nearby or be used in conjunction with another antenna or transmitter.

MPH-AC006B product model incorporates a module that meets Industry Canada's requirement set limits.

- IC: JQ6-SE3210

### *ATTENTION POUR LES UTILISATEURS AU CANADA*

Cet appareil est conforme aux normes RSS exemptes de licence d'Industrie Canada. Son fonctionnement est soumis aux deux conditions suivantes:

- (1) cet appareil ne doit pas provoquer d'interférences, et
- (2) cet appareil doit accepter toute interférence, y compris les interférences pouvant entraîner un fonctionnement indésirable de l'appareil.

Conformément aux réglementations d'Industry Canada, les émetteurs radio de cet appareil ne peuvent fonctionner qu'à l'aide d'une antenne dont le type et le gain maximal (ou minimal) pour ces émetteurs - transmetteurs sont approuvés par Industry Canada. Pour réduire le risque d'interférence éventuelle pour les autres utilisateurs, le type et le gain de l'antenne doivent être choisis de manière à ce que la puissance isotrope rayonnée équivalente (p.i.r.e.) minimale nécessaire à une bonne communication soit fournie.

Cet appareil est conforme aux limites d'exposition aux rayonnements IC établies pour la population générale (exposition non contrôlée). Cet appareil ne doit pas être colocalisé ou fonctionner en conjonction avec une autre antenne ou un autre émetteur.

Remarque: UL LLC n'a pas vérifié la conformité de ce produit aux normes canadiennes.

Le modèle de produit MPH-AC006B comprend un module conforme aux limites établies par Industrie Canada

- IC: JQ6-SE3210

## 1.6 > Others recommendations

### ***Potential safety conditions notice***

If you notice any of the following conditions (or if you have other safety concerns), do not use the product: crackling, hissing, or popping sound, or a strong odor or smoke coming from the product. It is normal for these conditions to appear when an internal electronic component fails in a safe and controlled manner. However, these conditions may also indicate a potential safety issue. Do not assume it is a safe failure. Turn off the product, disconnect it from its power source, and contact technical support for assistance.

### ***Disposal of waste equipment by users***



This symbol means do not dispose of your product with your other household waste. Instead, you should protect human health and the environment by handing over your waste equipment to a designated collection point for the recycling of waste electrical and electronic equipment.



## 1.7 > Recommendations for terminal implementation

Every installation is unique. Sometimes the issues are well defined and can be handled in a standard fashion; sometimes the issues are very specific and may not be immediately recognizable.

Idemia recommends following these steps for a successful installation:

**Plan the installation** - Choose the type of hardware required, decide if a network is required, and decide on the location and number of required terminals.

**Unpack all items** - Unpack all items and check against the packing list.

**Install network hardware components** - Install the cabling and components needed to run the system.

**Install software** - Install the software needed to set up the terminals.

**Pre-configure device** - Connect the terminals to the Ethernet, supply power to the terminals, and pre-configure the terminals.

**Mount devices** - Mount the terminals in their final locations

**Power distribution and device hook up** - Connect the terminals wiring via the back panel.

**Power-up procedure** - Check the power connections, and then start the system safely. First Boot Assistant screen is displayed, where you can perform **fundamental** configuration.

To secure properly an access, Idemia recommends installing the VisionPass terminal as a part of the typical Access Control environment described in the figure below.

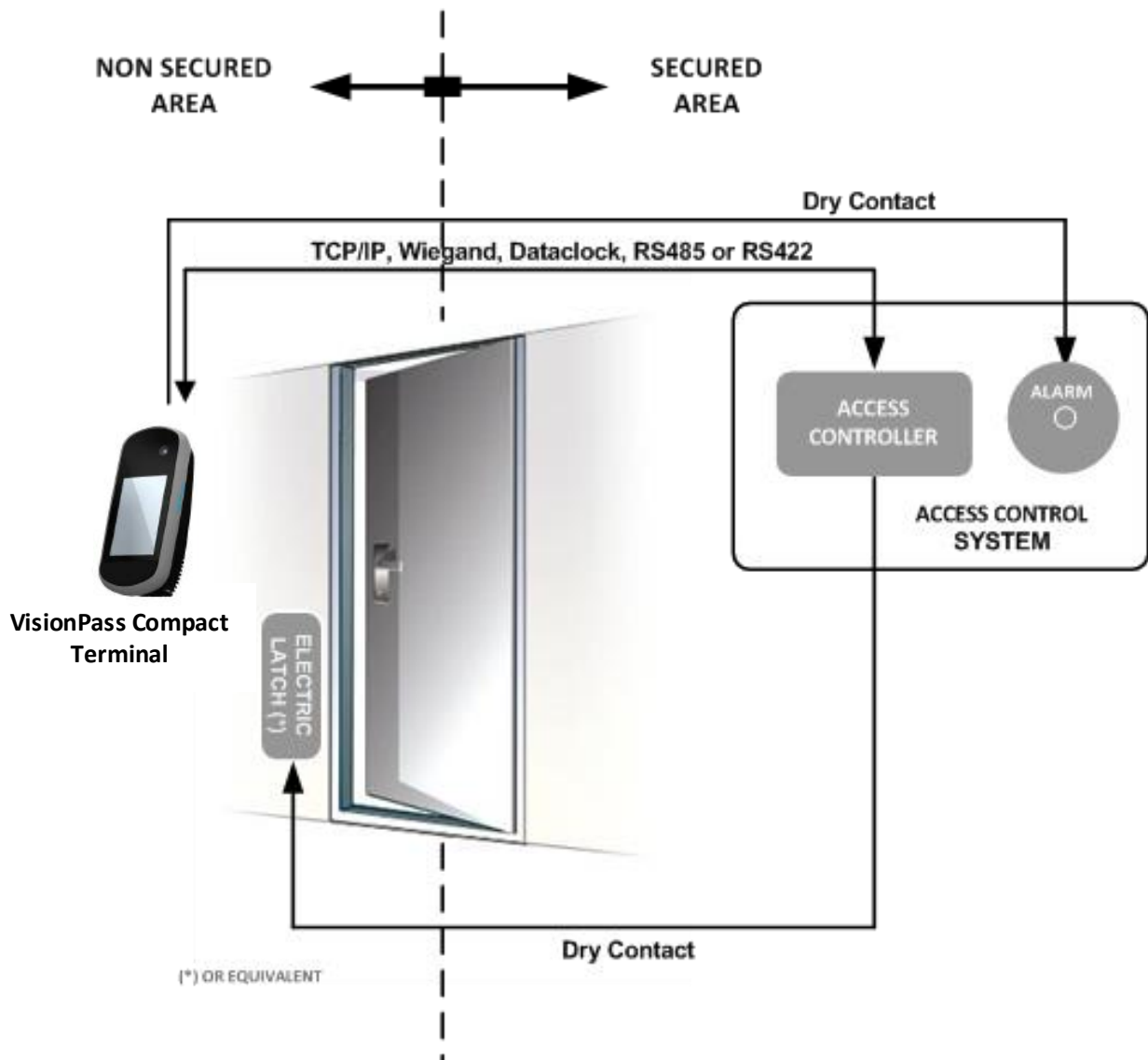

**Figure: Implementation Recommendations**

This environment comprises:

***The VisionPass terminal itself***

Its role is to perform one-to-many biometric identification or one-to-one biometric verification, i.e. to identify the individual who is presenting his face by comparing his biometric data with the references previously stored in the terminal database (in the form of biometric templates) or to verify his identity using the reference stored in a contactless card presented to the terminal.

***An Access Controller (3rd party product)***

The Controller is the element which controls the access rights of the individuals to the secured area. For that reason, it must be located in the secured area.

The individuals who are authorized to access the secured area have their User ID listed in a so-called "Authorized User List" (in contrast with a banned card list).

The VisionPass terminal and the Controller are communicating according to one of the TCP/IP, Wiegand, Dataclock or RS485 protocols:

The VisionPass terminal sends User ID to the Controller

The Controller sends its decision to the VisionPass terminal (which displays access granted or access denied depending on the answer)

The VisionPass terminal sends an alarm signal to the Controller as soon as a malicious operation is detected (terminal pulled out from the wall or opened for maintenance operations); refer the paragraph dealing with anti-pulling and anti-tamper switches for more explanations.

The Controller is part of the global Access Control System of the secured area, which can provide useful features such as manage:

Authorized user lists (i.e. for VIP),

Banned card lists (i.e. for lost user cards),

An access request log (who and when, access granted or denied,..),

An event log (i.e. tamper detection, access control for evacuation of the building,...).

The VisionPass terminal is able to work alone, without Controller, but the protection level of the secured area is lower.

#### *An Alarm (3rd party product)*

This element is connected to the VisionPass terminal through a dry contact.

The VisionPass terminal sends the command to activate the Alarm as soon as a malicious operation (terminal pulled out from the wall or having its bottom cover opened out of maintenance operations) is detected; refer the paragraph dealing with anti-pulling and anti-tamper switches for more explanations.

#### *A Door Electric Latch or equivalent (3rd party product)*

This element once activated opens the access. The Controller is the one which sends the command to activate the latch if access is granted (i.e. if the individual's User ID is listed in the Controller Authorized User List). Connection between these two elements is done through a dry contact.

---

## 2 / General description

## 2.1 > Box opening

At the box opening, components shall be extracted from the protection casing as depicted in the pictures below.

Extract the wall plate (which is not screwed to the terminal) and keep it separate until the installation of the terminal is completed. The screwing of the product to the wall plate is the last stage of the installation.

**Figure 1: Box Opening**

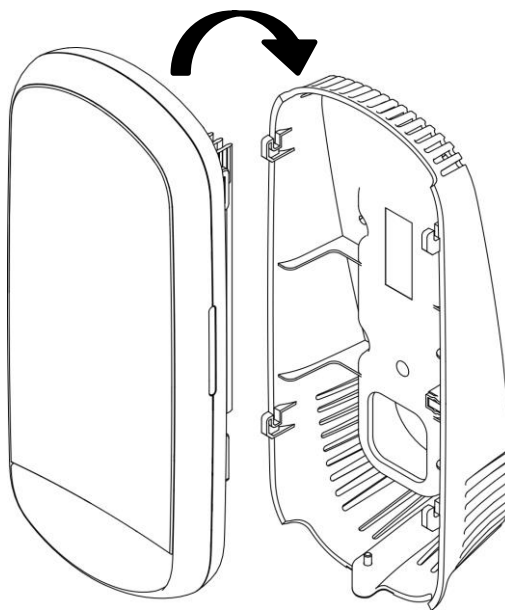

## 2.2 > Components of the initial package

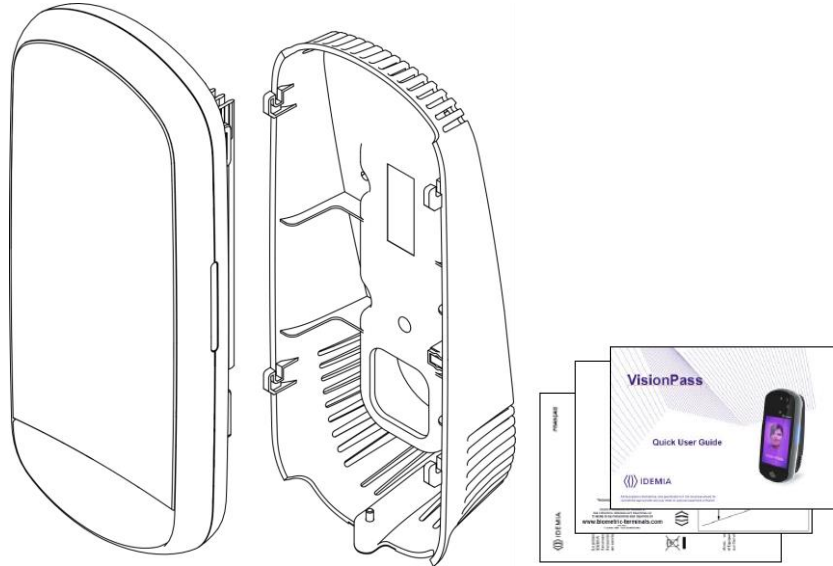

**Figure 2: Box Content**

1. One (1) Terminal's body
2. One (1) Wall frame
3. Documentation Package

## 2.3 > Terminal's front view description



**Figure 3: VisionPass terminal front view**

## 2.4 > Terminal's rear view description

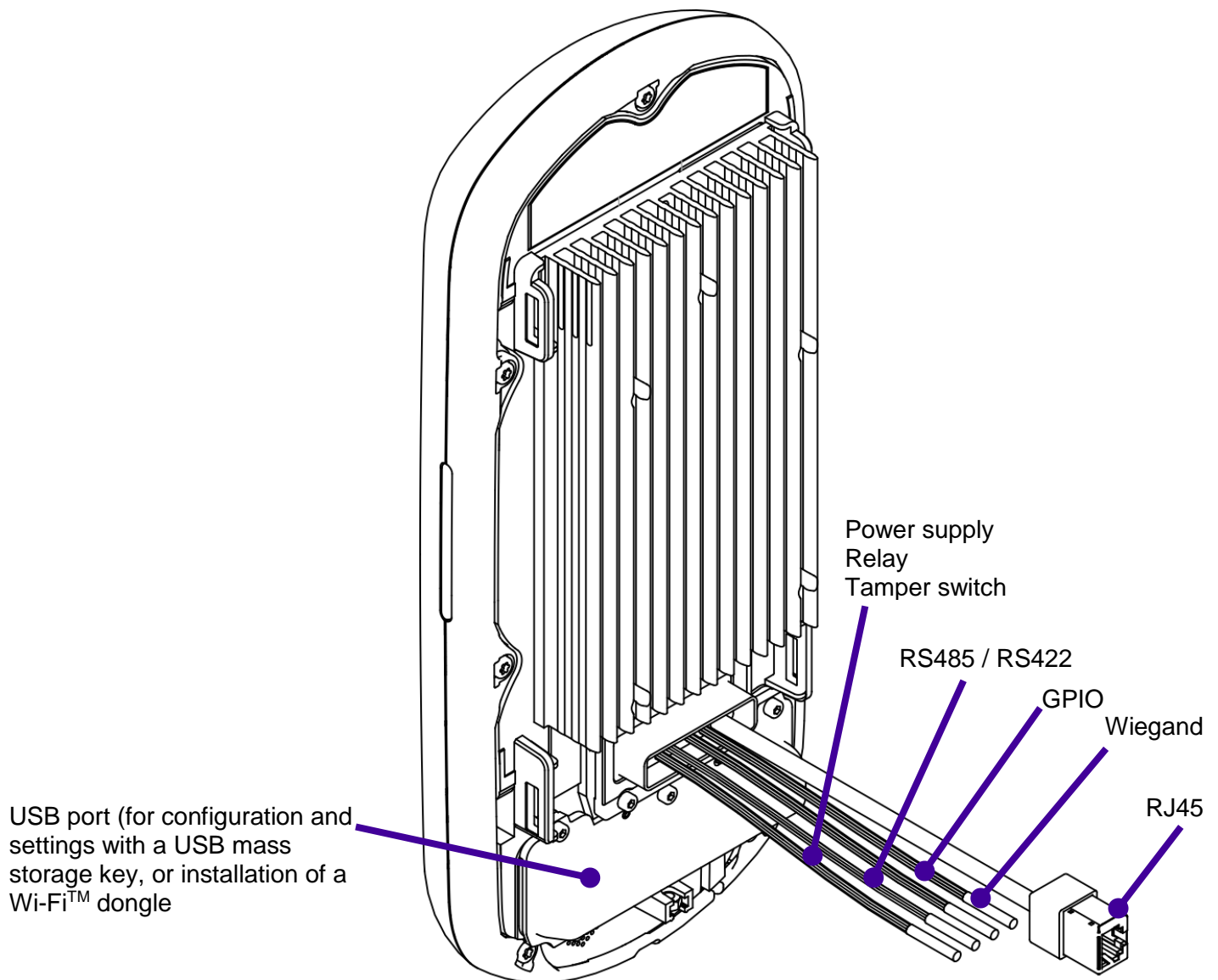

Figure 4: VisionPass terminal rear view



## 2.5 > VisionPass Technical Characteristics

Item	Description
Access control modes	Identification (search for faces in a local database)
	Authentication with contactless smartcard, with or without face check
	Multi-factor: identification or authentication
	Proxy: the access control check is fully driven by a remote system
Man Machine Interface	7" WVGA color capacitive Touchscreen
	Powerful Loudspeaker & Microphone
Biometrics	Face acquisition : Visible light and infra-red light 3D reconstruction
	False Acceptance Rate (FAR) adjustable from 1% down to 10 <sup>-7</sup> %
	Database capacity: 20 000 users (standard) and up to 40 000 users (with specific license)
Log capacity	1 000 000
LAN/WLAN connection	For terminal configuration and data transfer: Ethernet 10/100 Base T (MDI, MDI-X) Or Wi-Fi™ Wireless LAN (option), WEP, WPA (PSK) and WPA2 (PSK) encryption available Either TCP, SSL or TLS protocol

RFID cards (depending on product version)	MIFARE Classic 1KB & 4KB (4b and 7b UID) MIFARE Plus SL1 cards
	DESFire 3DES legacy 2K, 4K and 8K (EV0 & EV1) DESFire AES 2k, 4k, 8k (EV1)
	All HID iClass cards (incl. iClass legacy, iClass SR and iClass SE), except 2K2
	HID Prox 125 kHz whatever the format (26, 37 ....)
Serial port	The serial port supports WIEGAND, DATACLOCK (ISO2), RS422 and RS485 protocols
GPIO	3 GPI, 3 GPO
Output relay switches	Access granted: 1 switch two outputs (normally “open” and normally “closed”) 30V – 1A max (Resistive loads, 100 000 cycles)
USB host port	terminal configuration through a USB mass storage key connection with an external Wi-Fi™ USB dongle using an adapter cable
Input signals	LED1/LED2 to activate the access granted relay
Power supply	12 to 24 V DC power supply (3A min @12V) Note for UL 294 Compliance power supply shall be UL 294 and UL 294B with power limited output
Security of the terminal	Anti-tamper-pulling switches Tamper-pulling detection: one switch closed when product wall mounted, open when pulled out
Size and weight	W x H x D: 325 mm x 143 mm x 110 mm (12.8” x 5,6” x 4.3”) Weight : 2,1 kg

Environmental conditions	Operating temperature: -10 °C to + 45 °C (14°F to 113°F)
	Operating humidity 10 % < RH < 80 % (non condensing)
	Storage temperature -25 °C to + 70 °C (-13°F to 158°F)
	Storage humidity 5% < RH < 95 %
	The terminal should be installed in controlled lighting conditions Avoid direct exposure to sunlight or to UV lights

---

## 3 / Installation procedure

### 3.1 > Before proceeding to the installation

Make sure that you have all the components described in “Components of the initial package” section at your disposal.

Remove the wall plate. Keep this element at hand.

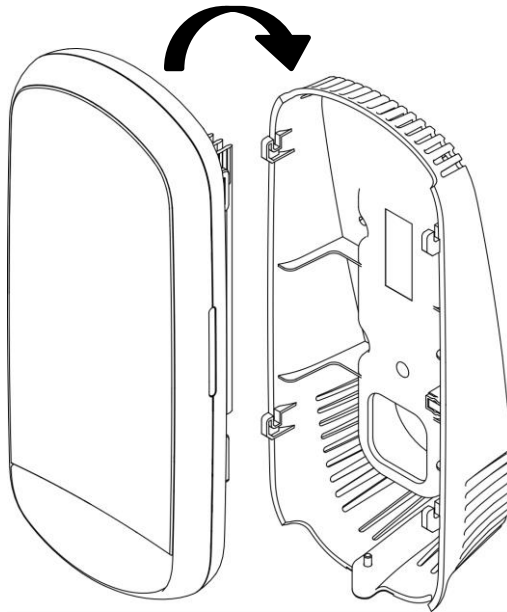

**Figure 5: Removing wall frame**

It is then possible to fix the terminal on the wall.



*For an optimal use the terminal must be installed in an area where the lighting conditions are controlled. Avoid direct exposure of the sensor to the sun light and ensure good ambient lighting for face detection if used.*

## 3.2 > Installation

### *Required tools (not supplied)*

Four (4) raw plugs + four (4) screws  $\varnothing$ 4mm max and length adapted to the wall material.

One (1) screwdriver adapted to screws above.

One (1) Drill (with a drill bit diameter adapted to raw plugs above).

One (1) hole saw (depending on installation case).

A (1) CHC H2 screwdriver

A (1) CHC H2.5 screwdriver

Deadbolt/door strike

Snubber diode required to protect regulated DC power supply from inductive kickback (1N4007 diode or equivalent recommended)

Separate power supply for the deadbolt/door strike based on supplier's recommendations.

External relay (if required)

Networking cable

For UL-294 compliance, an earthed screen in the wire or around all wires to/from product is only required when the wires share space/compartment/tube with high voltage cables.

### *Equipment from the initial package to use*

One (1) Terminal's body.

One (1) wall plate.

### 3.3 > Step by step procedure

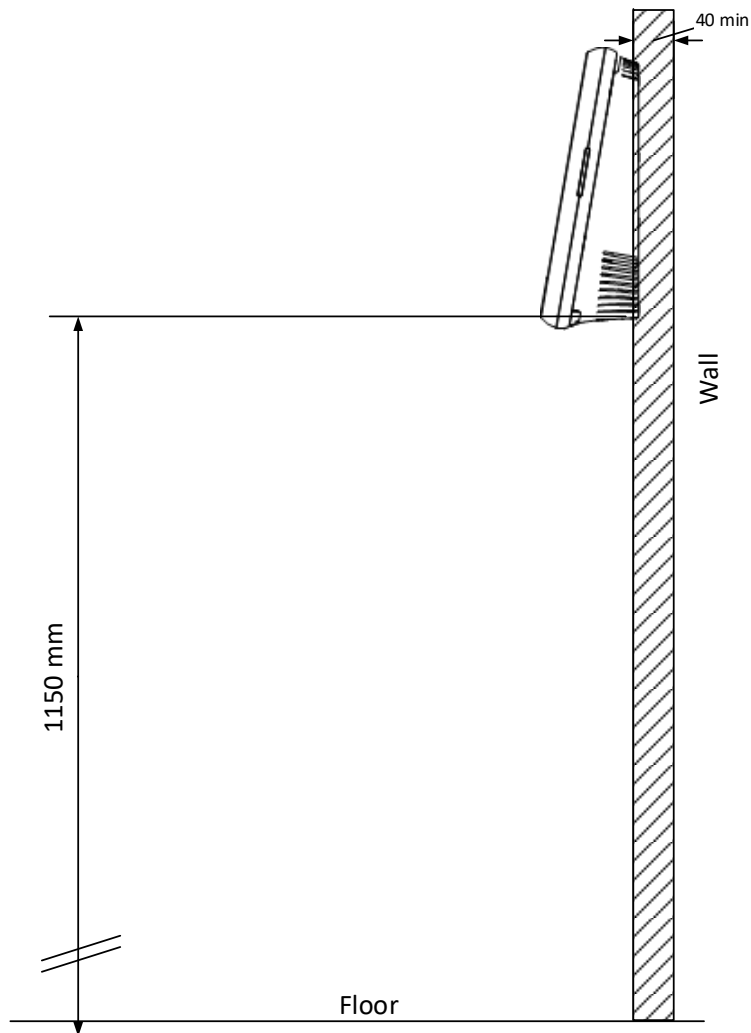

**Figure 6: Face camera viewing angle**

The recommended height for fixing of the terminal is 1.15 m (height of the bottom of wall frame).



*For an optimal use the terminal must be installed in an area where the lighting conditions are controlled. Avoid direct exposure of the sensor to the sun light.*



*Power supply from electrical source shall be switched off before starting the installation.*



*The strength of the attachment depends on the solidity of the wall on which the terminal is mounted.*

### 3.3.1 > Drill the mounting holes



*Be sure that the wall behind the wall plate has a good flatness.*

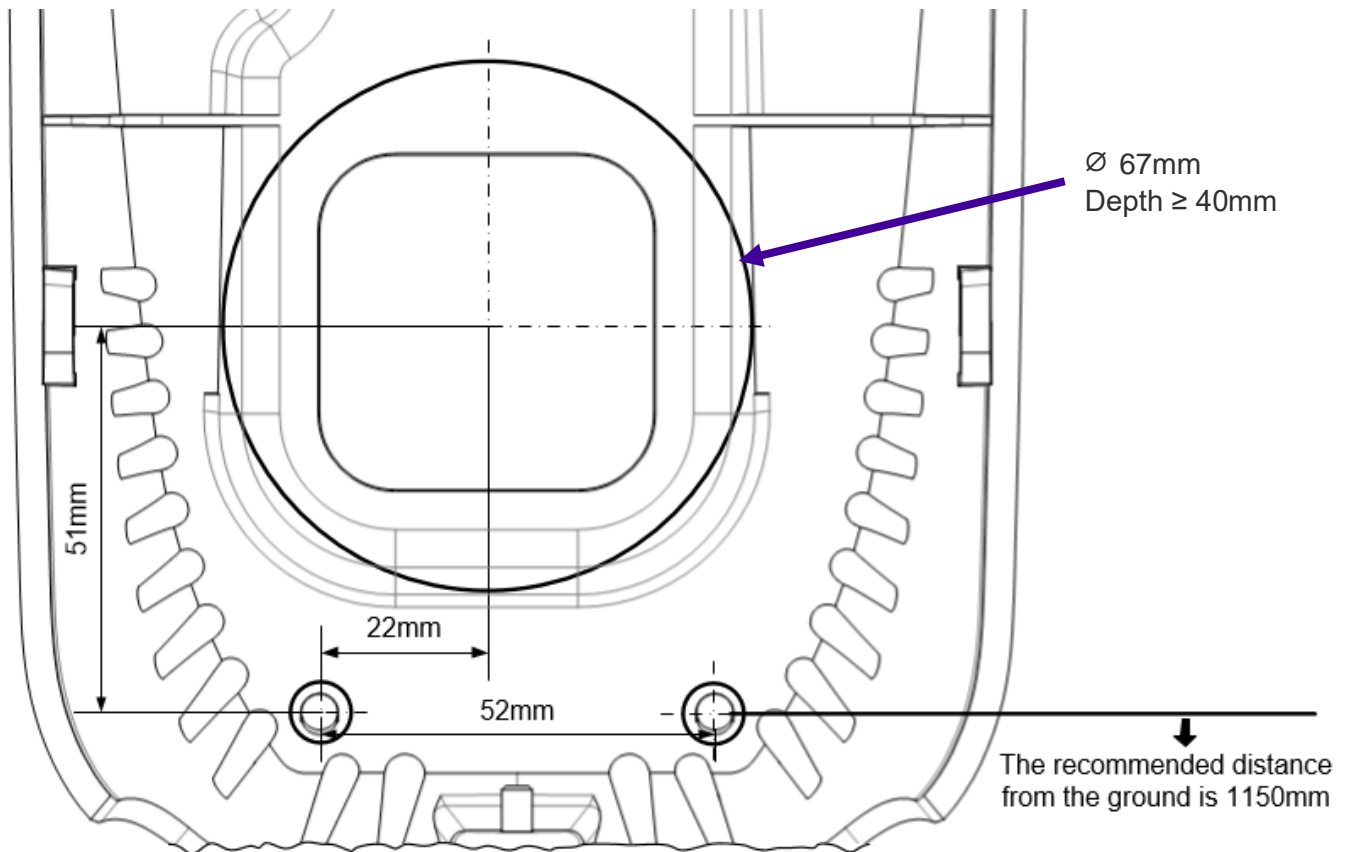

**Figure 7: Drilling template**

If not present, drill in the wall a hole with a diameter adapted to the width of the terminal and the cable to be hosted in (see Figure 7: Drilling template. This template can be found in the Quick Installation Guide).

The 67 mm diameter hole (cf. drilling template) should be at least 40 mm deep in order to fit the connections and cables. A deeper hole as recommended is possible, to make the connection process easier.

Confirm the presence inside the hole of all the cables needed for the electrical installation.

Drill in the wall 4 holes with a diameter adapted to screws and fit them with the raw plugs (see Figure 7: Drilling template).



*Be sure that a sufficient space is reserved in the wall for the passage of cables, in particular for Ethernet.*



### 3.3.2 > Make the connections

Unscrew the connector from the device:

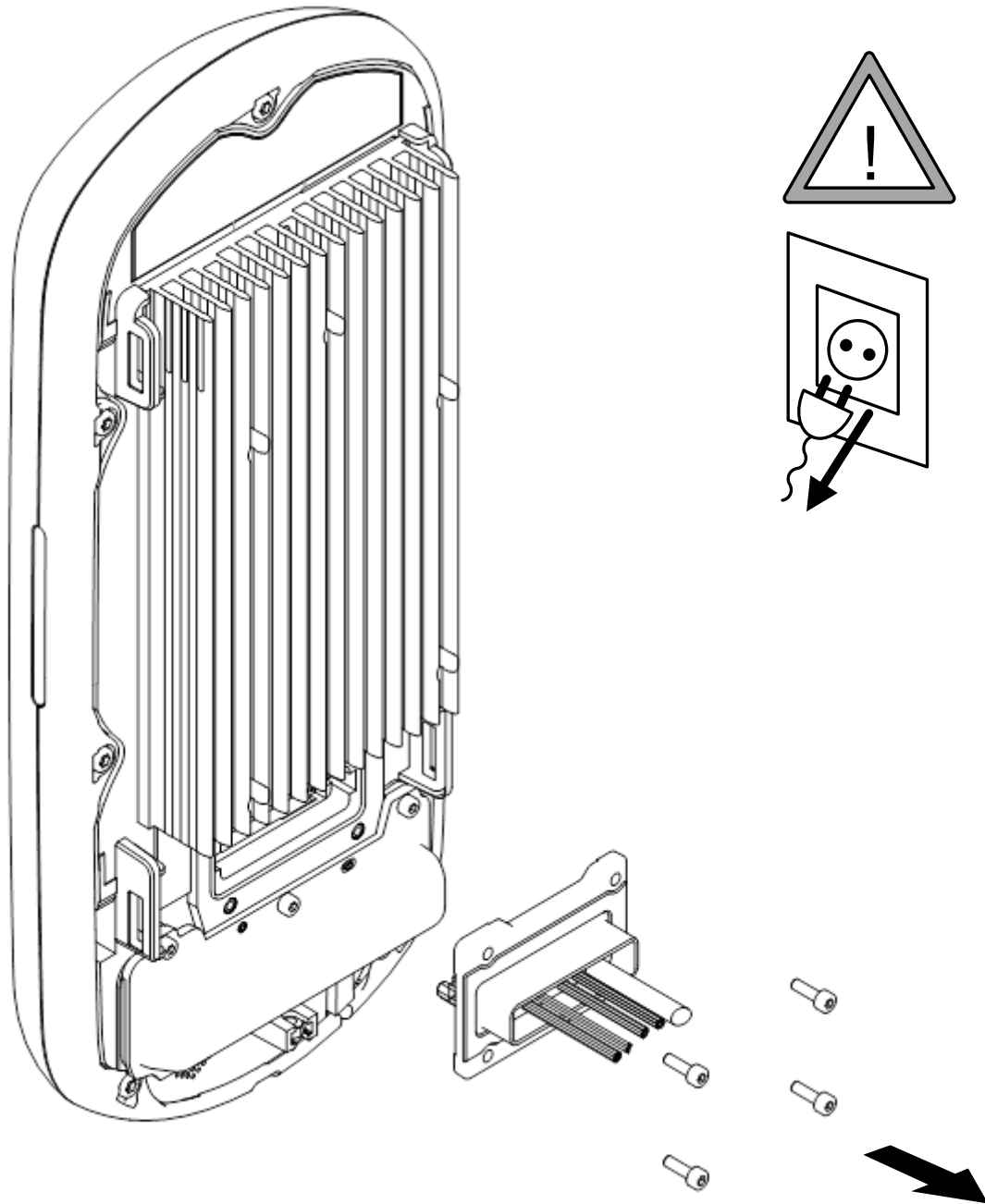
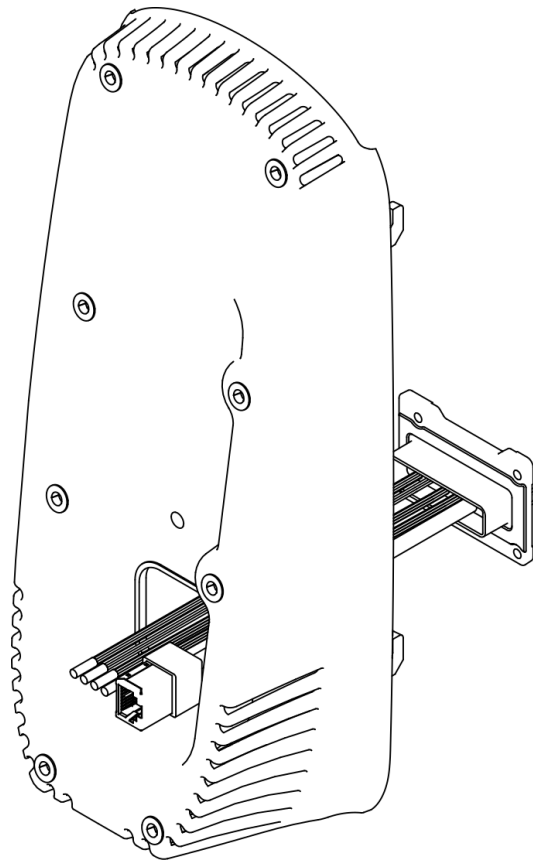

Figure 8: Connection - Step 1

Fit the cables through the mounting plate:



**Figure 9: Connection - Step 2**

Then connect the cables:

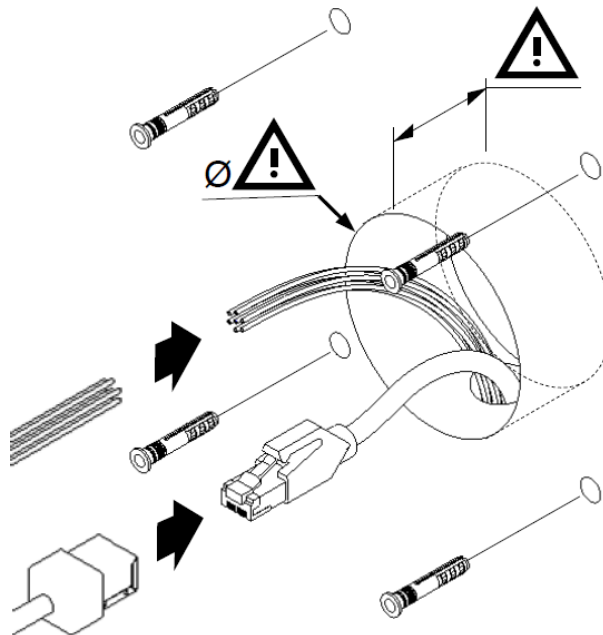

**Figure 10: Drilling template and cable connection**

Before cabling the product, remove the connector by cutting cables in the middle of heat shrink tube. Please refer to section 4 / for explanations of how cables/wires should be connected, according to wire color code.

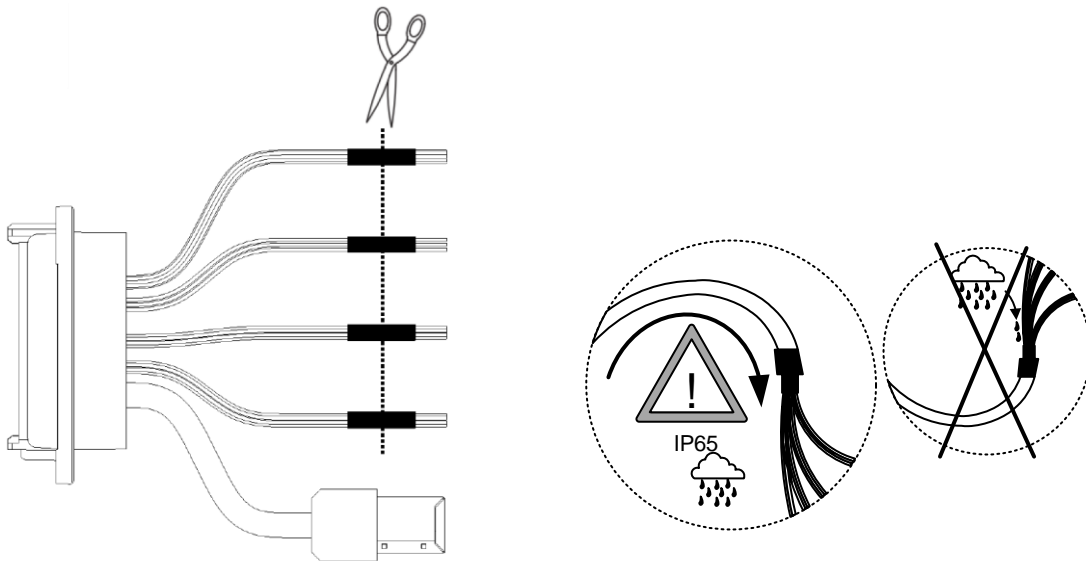

**Figure 11: Cable preparation : cable position for water tightness**

Cable for wiring shall be AWG 20 to 24, length shall be adapted to the size of the hole in the wall, to terminal connections, and to the distance between the electric source and the terminal itself.

For power supply, IDEMIA recommends using a 24V power supply and AWG16 gauge cable.



*To ensure water tightness, be sure to bend the cable downward.*

For test purpose, it is possible to use the existing connector without cutting it. This connector mates with Molex PCB header reference 5016452620. The pinout of this connector is described in this document in section 4 /.

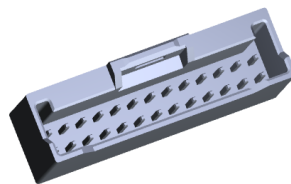

*The pinout indications that you can see on the labels of the cable shall NOT be taken into account as they correspond to the OTHER connector on the device side. Please use only the pinout information given in this document in section 4 /.*

### 3.3.3 > Attach the base plate on the wall

Fix the base plate on the wall with the 4 screws.

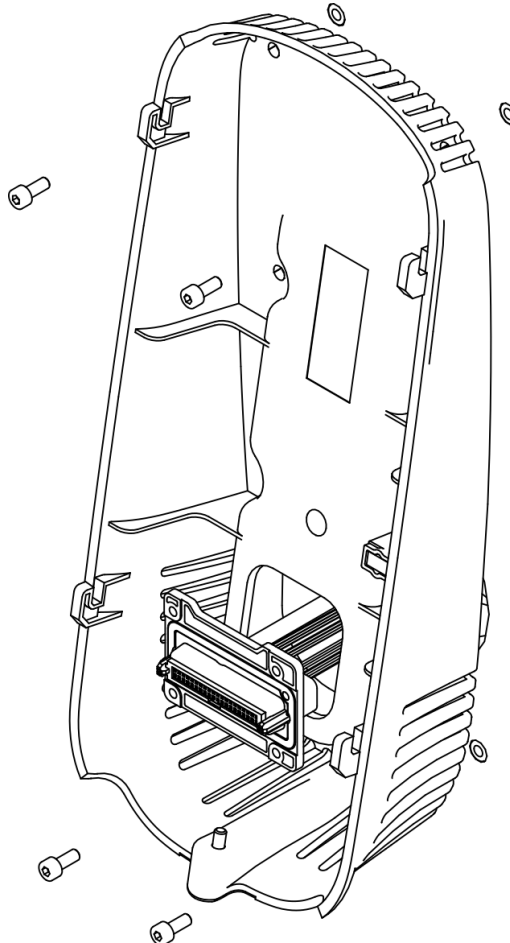

**Figure 12: Base plate fixation on the wall**

### 3.3.4 > Attach the device on the base plate

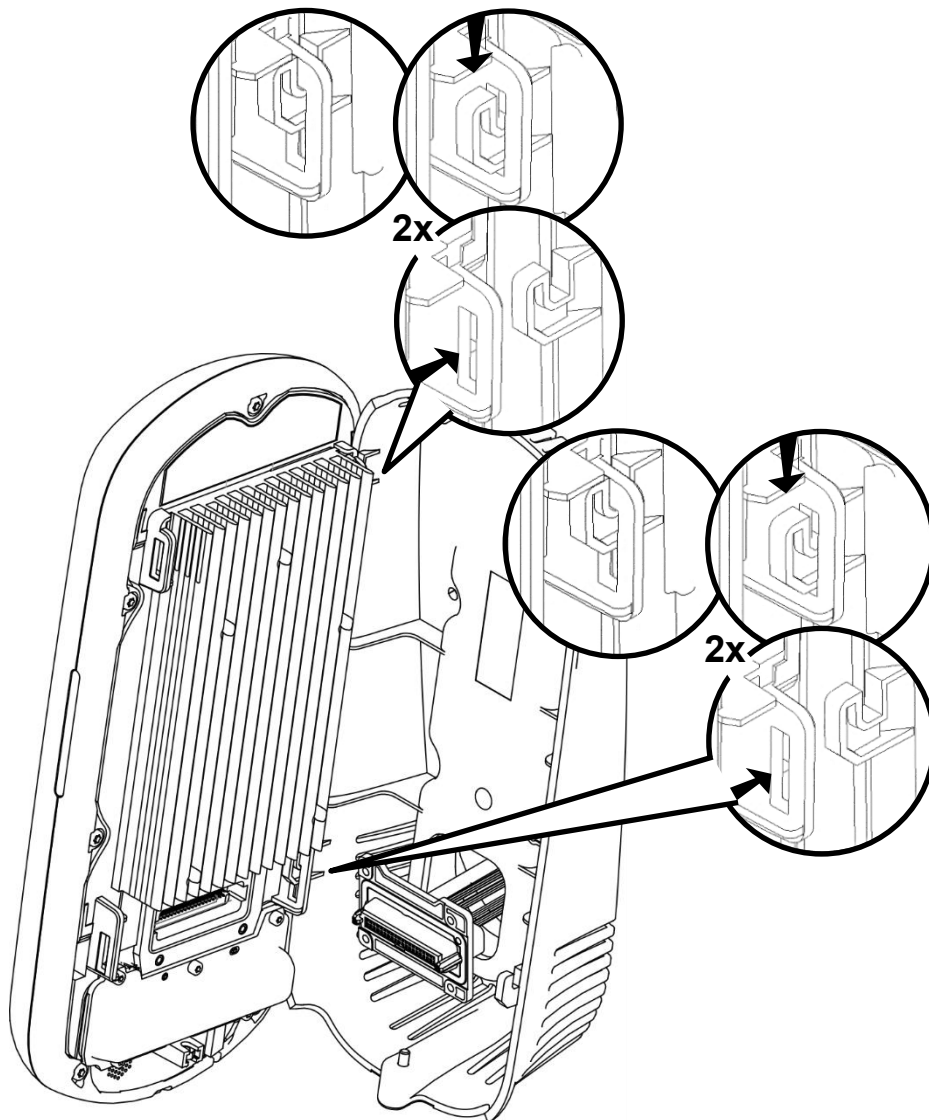

### 3.3.5 > Connect the connector assembly on the device

Attach the connector assembly on the device with the 4 screws.

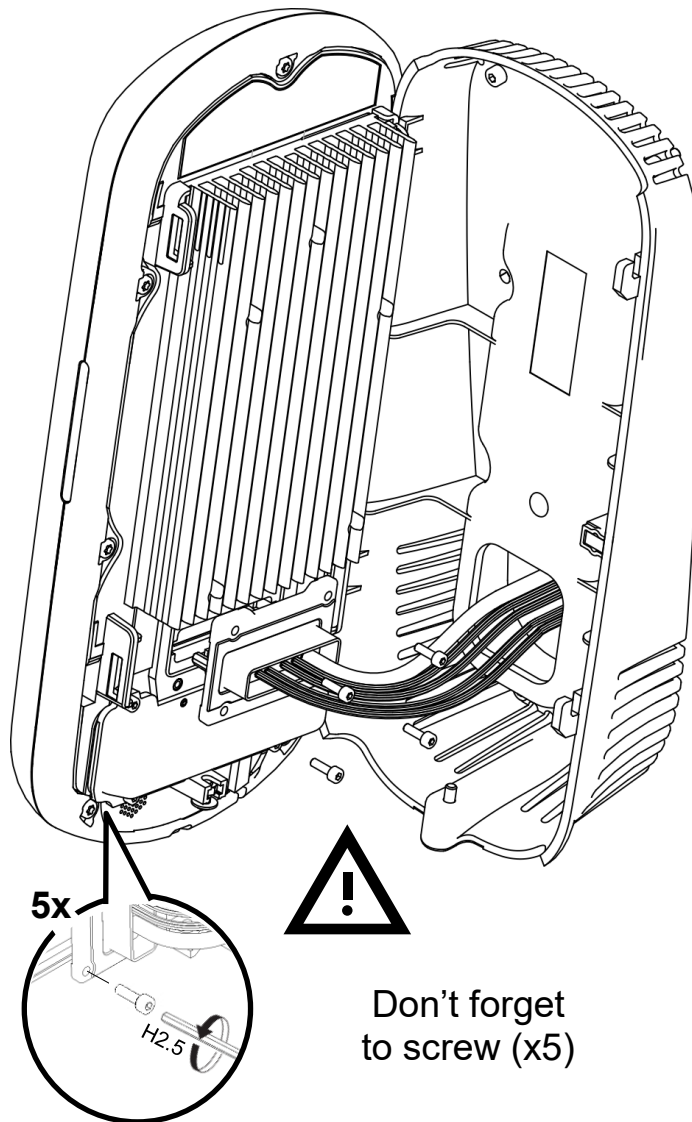

Figure 13: Connector assembly on the device

### 3.3.6 > Close the device on the base plate

Detach the device from the plate: first lift the device upwards, then pull it towards you, and hold it.

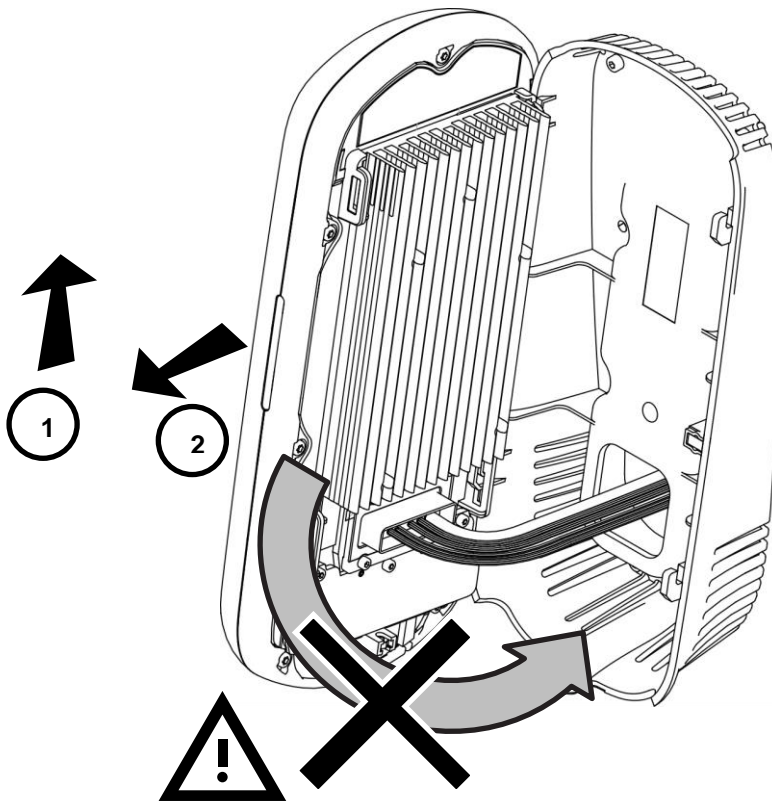
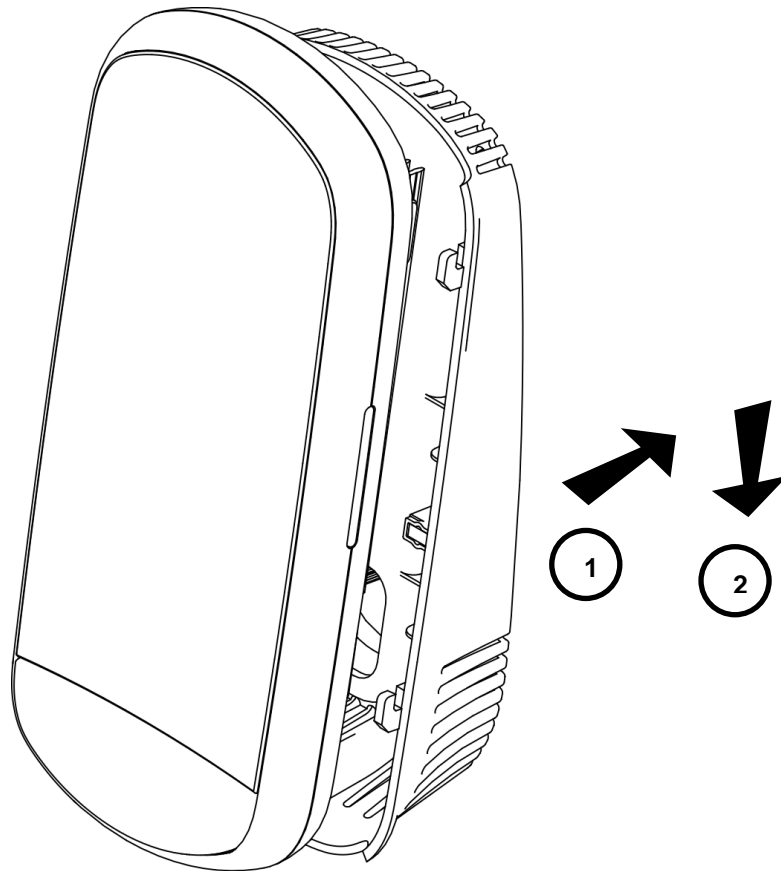

Figure 14: Product closure



*Do not try to turn the product directly while it is attached on the base plate, as this would definitely damage the plate and the device !*

Then rotate the device 90° to align it in the final position in front of the plate. Push the device towards the wall, then downwards until the device is locked on the plate.



**Figure 15: Product fixation on wall frame**



Then to secure the device on the plate, attach the last screw on the bottom of the device:

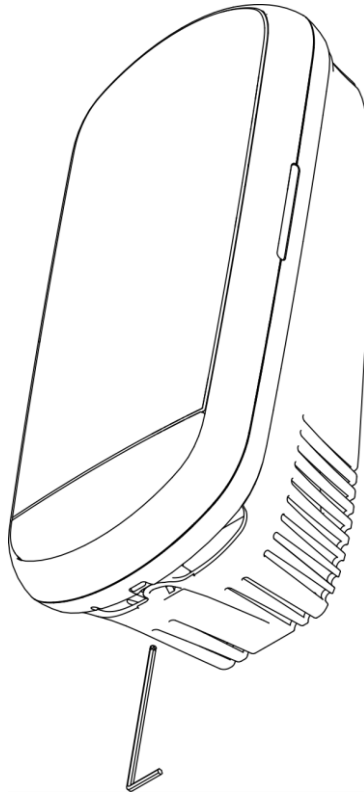

**Figure 16: Locking the product**

The hardware installation of the product on the wall is complete !

Power can be switched ON just after closing it. If the product has to be stored for a long time (more than 48 hours), don't forget to restore its configuration before use.

---

## 4 / Electrical interface

## 4.1 > Wiring overview



Before proceeding, make sure that the person in charge of installation and connections is properly connected to earth, in order to prevent Electrostatic Discharges (ESD).



Power supply ground shall not be used for peripheral ground. All other grounds can be used indifferently.

Note that all connections of the VisionPass terminal described hereafter are of SELV (Safety Electrical Low Voltage) type.

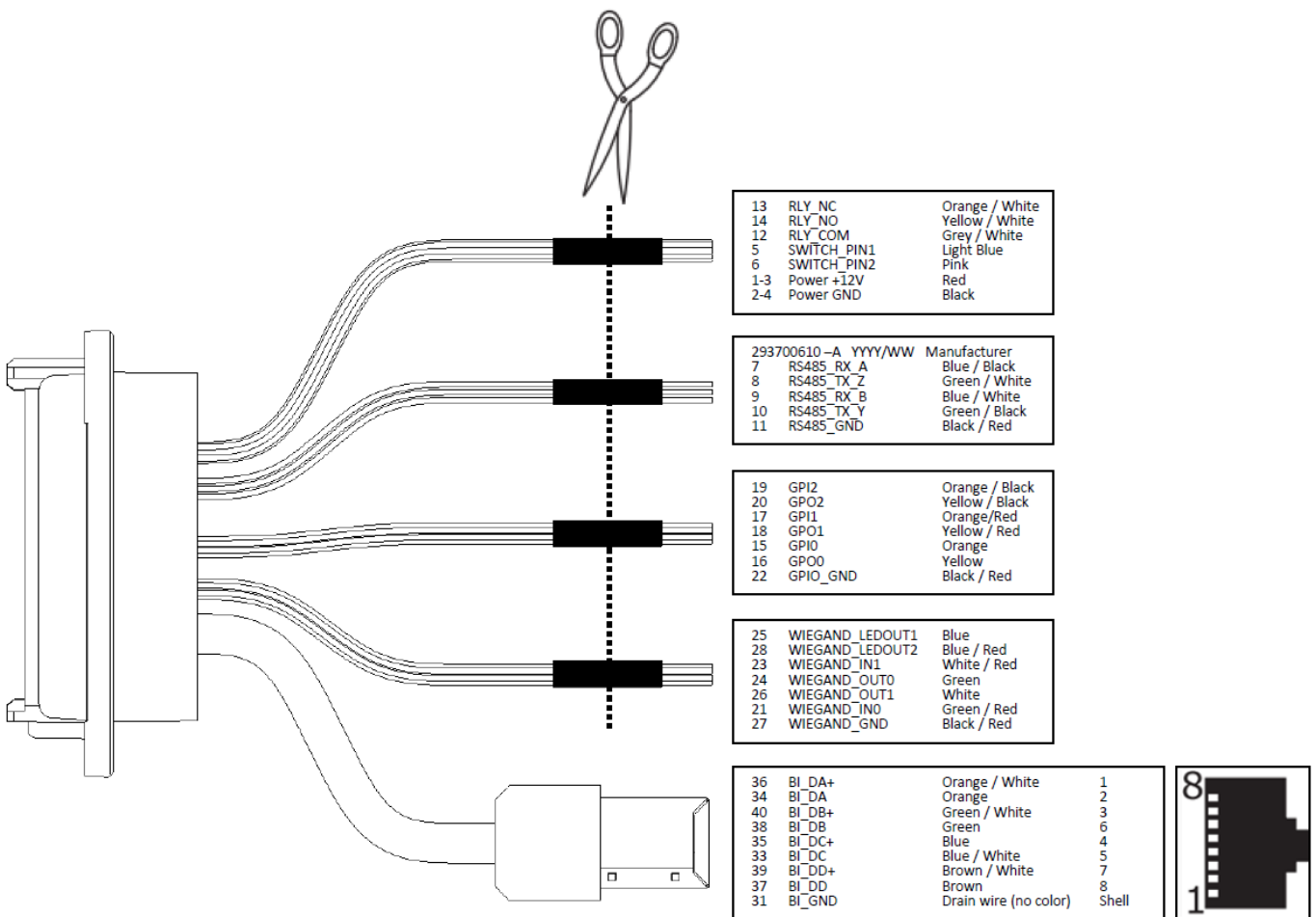
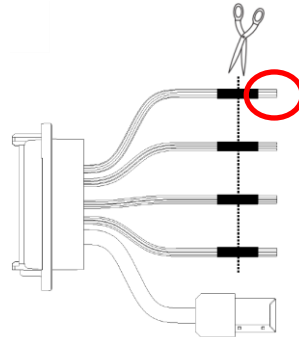

Figure 17: Cabling layout

## 4.2 > Power Supply

### External Power supply



1-3	Red	Power Supply 12-24V DC	In	Positive 12-24 Volts, power supply
2-4	Black	Power ground	In	Ground power supply

**Figure 18: Power supply wiring**

The External power supply

Must comply with IEC 60950-1 or IEC 62368-1 standard marked Class 2, Limited Power source (LPS) 12V to 24V DC (regulated and filtered) 3A min at 12V.

If sharing power between devices, each unit must receive 3A (e.g. two units would require a 12VDC, 6A supply).

IDEMIA recommends using a 24V power supply and AWG16 gauge cable. The voltage measured on the product block connector of the terminal must be equal to 12V-24V (-15% / +10%).

The voltage drop due to the cable shall be taken into account. The table below shows as an example the maximum distance between power supply and one (1) unique device, depending on cable gauge and power supply rating.



Gauge AWG	Section (mm <sup>2</sup> )	Maximum distance (meters) vs power source rating			
		12 V +/- 10% 3,6 A	12 V +/- 5% 3,5 A	24 V +/- 10% 2 A	24 V +/- 10% 3 A
16	1.31	6 m	12 m	68 m	121 m
18	0.82	4 m	8 m	43 m	76 m
20	0.52	2 m	5 m	27 m	48 m
22	0.32	1 m	3 m	16 m	30 m

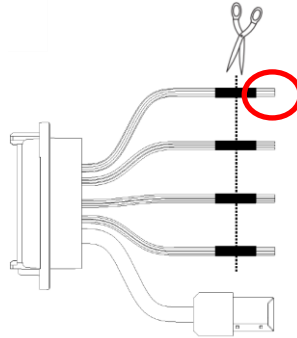

*If several terminals are powered by the same cable, make sure to select a wire gauge that complies with maximum voltage drop, cable length, and power source minimum voltage rating.*

### 4.3 > Output Relay



14	Yellow / White	RLY_NO		Contact relay (normally open)
12	Grey / White	RLY_COM		Contact relay common
13	Orange / White	RLY_NC		Contact relay (normally closed)

**Figure 19: Output relay wiring**

#### *Nominal characteristics of relay*

Load characteristics:

1 A max @ 30 VDC (according to the safety extra low voltage requirements independently of the power supply),

Resistive load or inductive load; see warning information hereafter for inductive load,

The internal relay is designed for at least 100 000 cycles (resistive load).



*Inductive load management requires a parallel diode for a better contact lifetime.*

#### *Example of connection for electrical door locks*

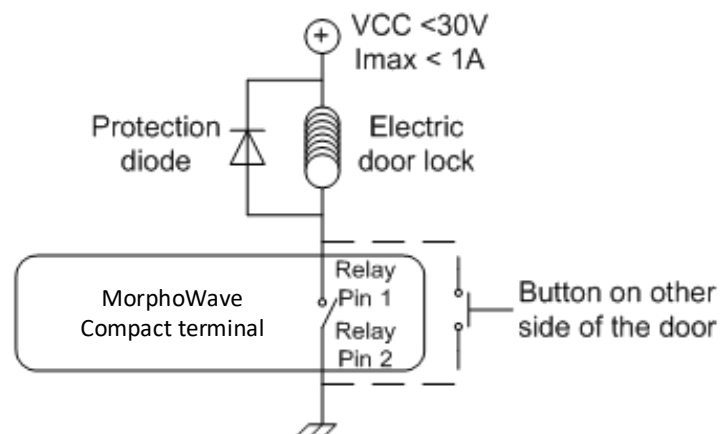

**Figure 20: Example of electric latch connection**

## 4.4 > Tamper Switch

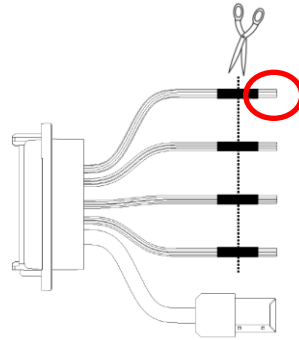

5	Light Blue	SWITCH_PIN1		Tamper switch contact
6	Pink	SWITCH_PIN2		Strip on tamper switch

**Figure 21: Tamper switch wiring**

### *Operating principle for the switch*

Product installed on the wall plate: switch enabled (contact closed).

Product opened (rear connectors accessible): switch disabled (contact open).

### *Nominal characteristics of switch block*

100 mA at 30 VDC max (Resistive load) according to the safety extra low voltage standard.



*This VisionPass terminal is part of security system; it is customer's responsibility to connect the tamper switch (contact) to physical access controller, in order to prevent the access to the connector blocks.*

## 4.5 > Wiegand wiring

### Wiegand input

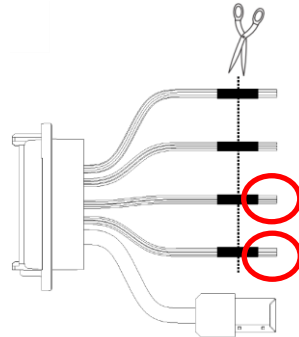

21	Green / Red	WIEGAND_IN0	In	Wiegand IN D0 (Output type required: Open drain or 5V+/-5%)
23	White / Red	WIEGAND_IN1	In	Wiegand IN D1 (Output type required: Open drain or 5V+/-5%)
16	Yellow	GPO0	Out	Wiegand LEDIN (typical = 5VDC) (option)
27	Black / Red	WIEGAND_GND		Ground for Wiegand

**Figure 22: Wiegand input wiring**



*If pull-up's to 12V have been added on Wiegand IN D0 and Wiegand IN D1 inputs on a previous installation with a MorphoAccess® 500 Series terminal, these resistors must be removed to avoid any damage to the VisionPass terminal.*

## 4.6 > Wiegand output

The following figure shows how to cable the wires of the serial port of the terminal for the Wiegand protocol

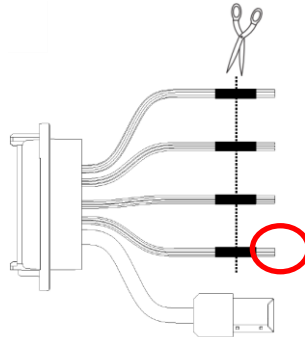

24	Green	WIEGAND_OUT0	Out	Wiegand OUT D0 (5V TTL)
26	White	WIEGAND_OUT1	Out	Wiegand OUT D1 (5V TTL)
25	Blue	WIEGAND_LEDOUT1	In	Wiegand LED IN 1 (option): panel feedback (Output type required: Open drain or 5V+/-5%)
28	Blue / Red	WIEGAND_LEDOUT2	In	Wiegand LED IN 2 (option): panel feedback (Output type required: Open drain or 5V+/-5%)
27	Black / Red	WIEGAND_GND		Ground for Wiegand

**Figure 23: Wiegand output wiring**

The use of LED1 and LED2 wires is described in the paragraphs below.

### *The controller supports neither LED1 nor LED2 signals*

When the access controller has no relay contact to provide an answer to the VisionPass terminal, then the decision to emit either the “access granted” signal or the “access denied” signal is taken by another way. It is either the VisionPass terminal itself that decide, or it waits for the access controller answer through the local area network (TCP), or on the serial port in (RS485 or RS422).

It is strongly recommended to disable the LED IN feature, to avoid any interference on VisionPass terminal behavior.

### *The controller supports only LED1 signal*

When the access controller has only one relay contact which is dedicated to the “access granted” answer, this one must be connected between the LED1 and GND wires. The LED1 wire is set to the low level by closing the contact between the LED1 and the GND wires, and it means “access granted”.

The VisionPass terminal uses the timeout of the wait for a low level on the on LED1 wire or LED2 wire as “access denied” answer.

To minimize at most the waiting time of the user, the VisionPass terminal timeout value, must be adjusted to a value a little bit higher than the maximal value of the controller response time.

**Warning:** if the LED2 wire is connected, it must be constantly maintained in the high state.



*The controller supports LED1 and LED2 signals*

When the controller supports one relay contact for each of the possible answers then:

The « access granted » contact must be connected between the LED1 and the GND wires of the terminal

The « access denied » contact must be connected between the LED2 and the GND wires of the terminal.

The VisionPass terminal considers that:

The answer of the controller is "access granted", when the controller puts the LED1 wire to the low state (by closing a contact between the LED1 and the GND wires), **and leaves the LED2 wire to the high state.**

The answer of the controller is "access denied", when the controller puts the LED2 wire to the low state (by closing a contact between the LED2 and the GND wires), **whatever is the state of the LED1 wire.**

The VisionPass terminal also considers that the answer of the controller is "access denied" in case of time-out while expecting for a closure between LED1 and GND wires, or between LED2 and GND wires.

## 4.7 > Serial port wiring

### DataClock Input

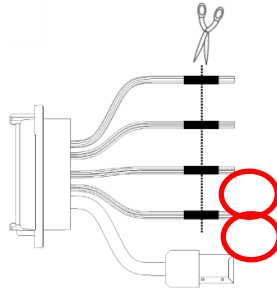

21	Green / Red	WIEGAND_IN0	In	Data (Output type required: Open drain only)
23	White / Red	WIEGAND_IN1	In	Clock (Output type required: Open drain only)
16	Yellow	GPO0	Out	Card present signal (if configured, only one selectable for Morpho Legacy)
27	Black / Red	WIEGAND_GND		Ground for Wiegand

**Figure 24: Serial port wiring – DataClock Input**

### DataClock Output

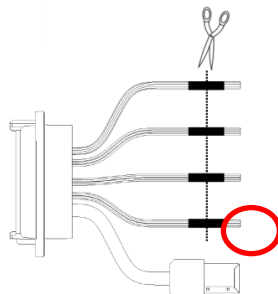

24	Green	WIEGAND_OUT0	Out	Data ( 5V TTL )
26	White	WIEGAND_OUT1	Out	Clock ( 5V TTL )
25	Blue	WIEGAND_LEDOUT1	In	LED IN 1 (option): panel feedback (Output type required: Open drain or 5V+/-5%)
28	Blue / Red	WIEGAND_LEDOUT2	In	LED IN 2 (option): panel feedback (Output type required: Open drain or 5V+/-5%)
27	Black / Red	WIEGAND_GND		Ground for Wiegand

**Figure 25: Serial port wiring – DataClock Output**

### RS485

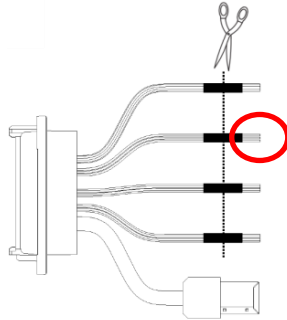

10	Green / Black	RS485_RX_A	In/Out	RS485 Rx/Tx non inverting signal
8	Green / White	RS485_RX_B	In/Out	RS485 Rx/Tx inverting signal
11	Black / Red	RS485_GND		Ground

**Figure 26: Serial port wiring – RS485**

RS485 implementation is limited to half-duplex communication. So only Tx+, Tx- and ground reference signals are necessary.

Depending on the RS485 network, an impedance adaptation may be required.

For farthest terminal, a 120-Ohms resistor termination may be added outside the terminal between TX+ and TX-.

### RS422

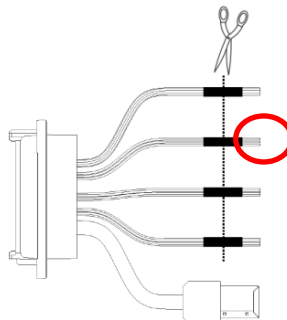

7	Blue / Black	RS422_RX_A	In	RS422 non inverting Receive
9	Blue / White	RS422_RX_B	In	RS422 inverting Receive
10	Green / Black	RS422_TX_Y	Out	RS422 non inverting Transmit
8	Green / White	RS422_TX_Z	Out	RS422 inverting Transmit
11	Black / Red	RS422_GND		Ground

**Figure 27: Serial port wiring – RS422**

RS422 interface is a full duplex communication.

## 4.8 > GPIO wiring

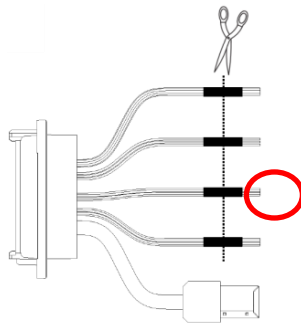

19	Orange / Black	GPI2	In	Digital Input (1,8V to 5V)
20	Yellow / Black	GPO2	Out	Digital Output (5V – 5mA max)
17	Orange / Red	GPI1	In	Digital Input (1,8V to 5V)
18	Yellow / Red	GPO1	Out	Digital Output (5V – 5mA max)
15	Orange	GPI0	In	Digital Input (1,8V to 5V)
16	Yellow	GPO0	Out	Digital Output (5V – 5mA max)
22	Black / Red	GPIO_GND		Ground

**Figure 28: GPIO wiring**

### Single Door Access Control (SDAC) implementation

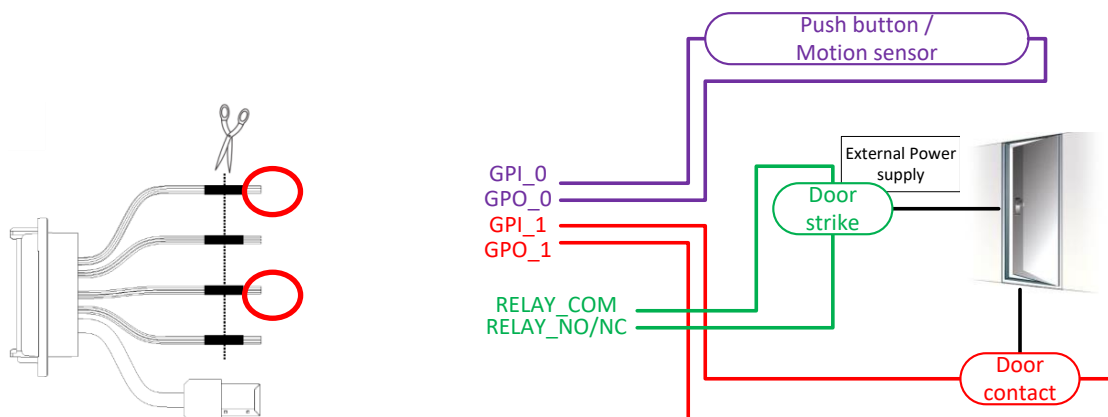

**Figure 29: SDAC wiring**



*If door contact is not used, GPI1 and GPO1 shall be connected together*

## 4.9 > Ethernet connection

Use a category 6 shielding cable (120 Ohms) or better. It is strongly recommended to insert a repeater unit every 90 m.

### Recommendations for RJ45 wiring

Pin	1	2	3	4	5	6	7	8
<b>Signals</b>	Data pair 1	Data pair 1	Data pair 2	NC/POE pin dedicated (+)	NC/POE pin dedicated (+)	Data pair 2	Ground/ pin dedicated (-)	NC/POE pin dedicated (-)
<b>EIA / TIA T568B Colors</b>	White orange	Orange	White green	Blue	White blue	Green	White brown	Brown
<b>EIA / TIA T568A Colors</b>	White green	White green	White green	White green	White green	White green	White green	White green
<b>Corel L120 Colors</b>	Grey	White	Pink	Orange	Yellow	Blue	Purple	Brown

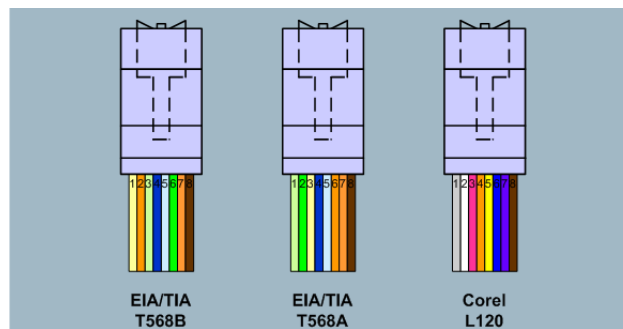

**Figure 30: RJ45 wiring**

RJ45 plug pinout is compliant with 10/100 base T, IEEE802.3 Specification. Product is compliant also with MDI or MDI-X.



*Ethernet cable shall be shielded*

### Default Ethernet configuration

By default, VisionPass terminal is configured in STATIC mode with the following configuration: IP Adress : 192.168.1.10; Gateway Adress : 192.168.1.254; Subnet Mask : 255.255.254.0

## 4.10 > Internal USB connection

Remove the 4 screws of the cover, as shown on the following drawing. Then remove the cover.

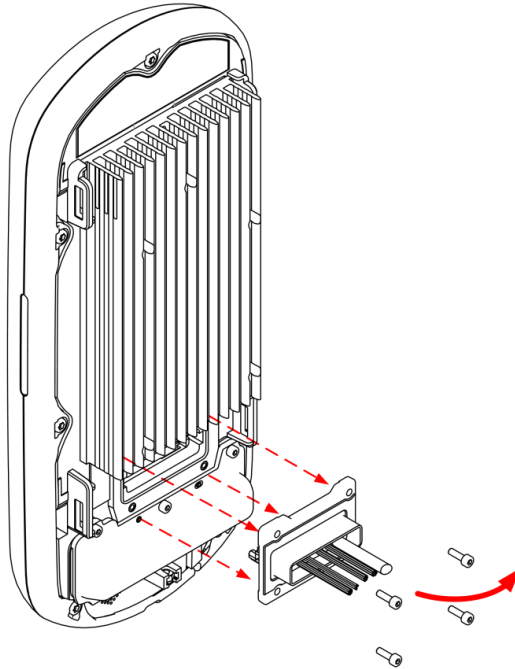

**Figure 31: Cover removing**

Then you can see a Mini USB plug.

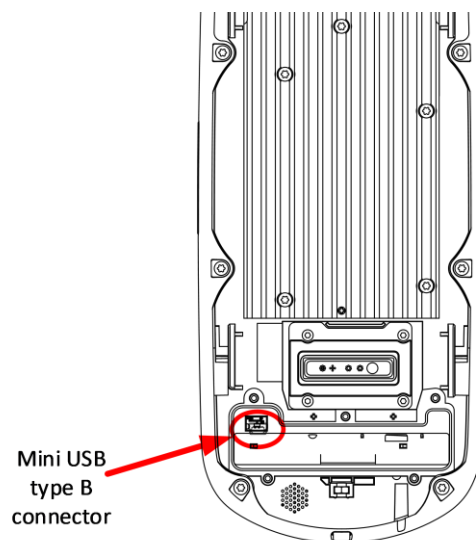

**Figure 32: Internal USB connection**

The internal Mini USB-type B can be used for administration only to connect a mass storage USB key (with a standard Mini USB-type B / USB-type A female OTG adapter).

Please refer to VisionPass Administration Guide for more information.



*USB connection is limited to USB key connection (power consumption shall not exceed 200mA)*

## 4.11 > Wi-Fi™ dongle installation

Wi-Fi™ dongle shall be installed inside the product and connected to the internal USB Mini B (at the rear of the terminal) using Idemia adapter provided in the kit.

Product integrating Wi-Fi™ dongle shall not be exposed to temperature exceeding 35°C and shall not be exposed to direct sun.

Only Wi-Fi™ USB dongle delivered by Idemia (kit reference 293761928, containing the dongle and the adapter) may be installed with the terminal for WLAN (Wireless Local Area Network) operation.

Remove the cover on the rear panel:

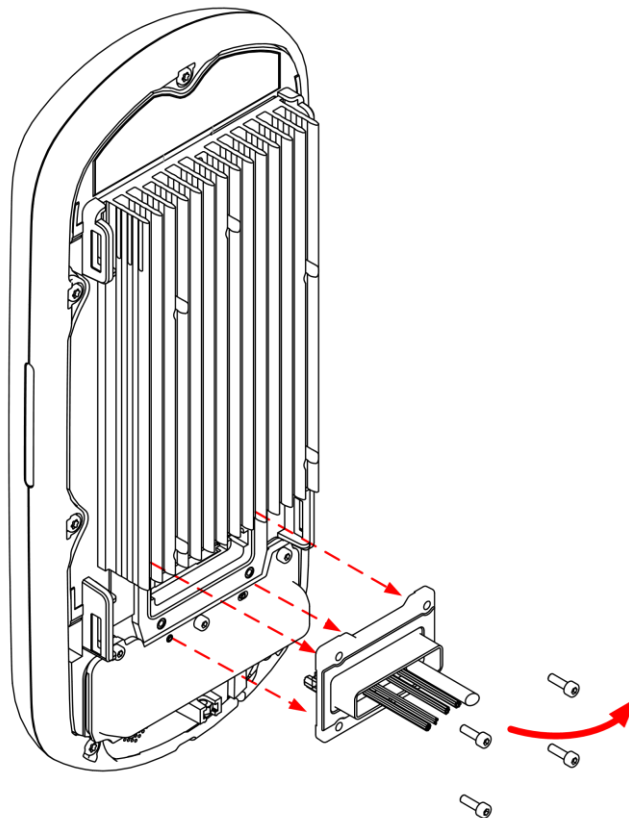

**Figure 33: Cover removing**



Then plug the Wi-Fi™ dongle on the provided adapter, connect the adapter on the Mini-USB socket, as described on the following picture:

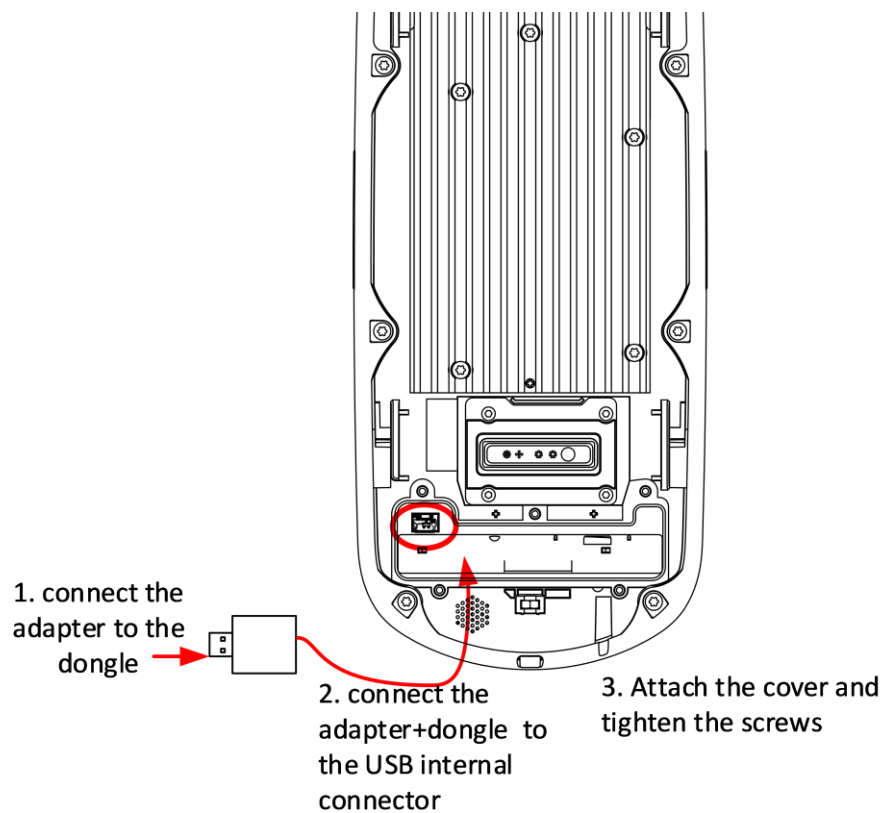

**Figure 34: Wi-Fi™ dongle installation**

Close the product with the cover and tighten the 4 screws.

---

## 5 / User interface

## 5.1 > Modes for controlling access rights

### 5.1.1 > Introduction

The VisionPass terminal offers several methods for controlling access rights: it needs to be configured in one of the following four modes:

- Identification mode,
- Authentication mode,
- Multi-factor mode,
- Proxy mode

Refer to VisionPass Administration Guide for more information on Access Control.

### 5.1.2 > Identification mode

The Identification process of the VisionPass terminal proceeds by comparison of the biometric data of the face placed on the biometric sensor, with all the biometric data stored in the database.

It means that the biometric data of the allowed users must be stored in the internal database before they can request the access on the terminal. This biometric data is acquired either directly on the terminal (using the embedded firmware), or on an enrolment system using the same type of biometric sensor.

The access control by identification process is started when a face is detected in front of the biometric sensor.

When the user requests the access, his identity is unknown, and it is the terminal that searches for his identity. The terminal grants the access if a match is found (the user is identified); otherwise the access is denied (the user remains unknown).

For further information, please see the "Identification mode" section in the VisionPass Administration Guide.

### 5.1.3 > Authentication (verification) mode

Unlike the "identification" mode, the user identity must be known in order to execute the authentication process.

Indeed, authentication is an identity verification process: the user provides his identity and the terminal checks it with the relevant process.

This mode doesn't compare the user's data to the data of several users: it compares the data provided by the user with the reference data provided by the same user during enrollment phase. The data can be on a card presented to the terminal or in a database and ID is provided by the user.

Access is authorized if the terminal finds a correspondence.

For further information, please see the "Authentication mode" section in the VisionPass Administration Guide.

## 5.1.4 > Multi-factor mode

In this mode, the "identification" and "authentication" modes are available simultaneously; the user decides which control method will be used:

- by presenting his face to the sensor, thereby triggering the identification process,

- by placing his contactless card on the reader, thereby triggering the authentication process,

This is the default mode for terminals fitted with a contactless smartcard reader.

For further information, please see the "Multi-factors method" section in the VisionPass Administration Guide.

## 5.1.5 > Proxy mode

The Proxy mode is an operating mode where the access control main application is located in a distant system. This is not a standalone mode like Identification and Authentication modes.

It means that the terminal becomes a slave of the host system application. The access control application is running on the host system and uses VisionPass terminal high level functions:

- Identification function

- Authentication function

- Read data on a contactless card

- Access control result signal command

The VisionPass terminal is driven through an Ethernet (or Wi-Fi™) link using TCP, SSL or TLS protocol.

The VisionPass terminal acts as a server: it is either waiting for a command or executing a command.

The commands allowed by the VisionPass terminal are described in the VisionPass Host System Interface Specification document.

For further details about SSL or TLS on the VisionPass terminal, please refer to the VisionPass Administration Guide.

## 5.1.6 > External database mode (also called polling mode)

When external database mode is activated, the VisionPass terminal does not verify user template in its local database. This mode is useful when the user templates are stored in external database.

When authentication is initiated on the terminal, the terminal will poll the user ID to external controller. On polling out the ID, the corresponding template (if exists) is fetched from the external database and is authenticated against user's biometric on the terminal. Once the template request is posted to the external database, the terminal shall wait for the face template from the external database to start authentication. Further process shall be same as authentication.

### *Polling Process using buffer:*

The user's input ID will be queued in the terminal's queue, which is polled by external application.

External application waits for the User ID by polling the buffer. After getting an ID, it will search the template in database and send template to terminal for further authentication.

The user is authenticated by the external device and granted access accordingly.

VisionPass terminal also has distant commands to retrieve polling buffer status and polling buffer data. Refer to the VisionPass Host System Interface Specification document.

### *How to Activate?*

External database mode can be activated by setting "ucc.enable\_external\_database" parameter to 1. Only an admin user can activate polling mode. You can refer to the VisionPass Host System Interface Specification document to know how to set this parameter.

## 5.1.7 > Anti-tamper / anti-pulling switches

Please refer also to "Tamper Switch" section.

These switches are activated as soon as there is enough pressure applied on the terminal against the wall. They are deactivated as soon as this pressure is not big enough, e.g. when the terminal is pulled out of the wall.

When the switches are deactivated, the VisionPass terminal acts as required by the related configuration key (see VisionPass Administration Guide for key configuration description):

- | Ignore the event (default): useful during normal maintenance operations.
- | Send an alarm message to the Central Access Controller, through the usual channel of the access control result messages (Wiegand, DataClock, RS485, Ethernet or Wi-Fi™). An alarm switch (relay contact) is directly available on block terminal «tamper switch pins». Please refer to "Wiring overview" and to "Tamper Switch" sections.
- | Generate an audible alarm signal with the speaker and an alert message on the screen.

---

## 6 / Accessories, Software Licenses and PC Applications

## 6.1 > Compatible Accessories, Licenses and Software

The following items can be ordered directly to Idemia or to an official distributor, so as to enjoy all the features of your VisionPass terminal:

Power supply units,

Contactless smartcards: MIFARE® 1k, 4k; DESFire® 2k, 4k, 8k,

WI-FI PACK: containing a Wi-Fi™ USB dongle and a Wi-Fi™ license to activate Wi-Fi™ capability on your terminal,

User database size licenses MA\_40K\_USERS : enabling database size upgrade from 20 000 to 40 000 users capacity at creation of the database.

## 6.2 > Compatible PC applications

VisionPass terminals are fully compatible with:

MorphoManager (version 14.3 or higher)

MorphoBioToolBox (version 4.4.1.0 or higher)



---

## 7 / Recommendations

### *Global warning*

The manufacturer cannot be held responsible in case of non-compliance with the following recommendations or incorrect use of the terminal.

### *General precautions*

Do not attempt to repair your terminal yourself. The manufacturer cannot be held responsible for any damage/accident that may result from attempts to repair components. Any work carried out by non-authorized personnel will invalidate your warranty.

Do not expose your terminal to extreme temperatures.

Use your terminal with original accessories. Attempts to integrate unapproved accessories to the terminal will void your warranty.

Due to electrostatic discharge, and depending on the environment, synthetic carpet should be avoided in areas where the terminal has been installed.

Do not tilt the product.

Do not use blunt force on the product.

Do not attach anything to the product.

Do not place anything on the product.

Switch off the device before unplugging it.

### *Biometric performance*

Do not scratch the product, particularly on the glass, because the performance of the product depends of the state of the glass surface and its anti-reflective face.

Clean the glass every day to optimize performance of the product.

Avoid direct sun light on the product.

### *Areas containing combustibles*

It is strongly recommended that you do not install your terminal in the vicinity of gas stations, petroleum processing facilities or any other facility containing flammable or combustible gasses or materials.

### *Specific precautions for terminals equipped with a contactless smartcard reader*

It is recommended to install terminals equipped with a contactless smartcard reader at a certain distance (> 30cm) from metallic elements such as iron fixations or lift gates or radio product (such as contactless smartcard reader). Performances in terms of contactless badge reading distance will decrease when metallic elements are closer.

### *Ethernet connection*

It is recommended to use a category 5 shielding cable (120 Ohms). It is also strongly recommended to insert a repeater unit every 90m.

Extreme care must be taken while connecting Ethernet wire to the terminal block board since low quality connection may strongly impact Ethernet signal sensibility.

It is recommended to connect Rx+ and Rx- with the same twisted-pair wire (and to do the same with Tx+/Tx- and the other twisted-pair wire).

### *Date / Time synchronization*

The terminal clock has a +/-10 ppm typical time deviation at +25°C (roughly around +/- 6 sec per 48 hours). At lower and higher temperature (but within normal operating temperatures), deviation may be more important (worst case: - 14 seconds per 48 hours).



If the terminal is used in an application requiring high time precision, we recommend synchronizing regularly your terminal time with an external clock (using NTP). Every 24 hours is usually enough for most applications.

Please note that the date/time of the terminal is protected from power failure during at least 24 hours. If the duration of the power failure or power down is longer, the date/time of the terminal will be lost.

#### *Cleaning precautions*

Use a dry cloth to clean the terminal, especially the front face. It is recommended that the product be cleaned daily to ensure the best performance level over its lifetime.

The use of acid liquids, alcohol or abrasive materials is prohibited.

Use dry air spray to remove the dust out of the sensor glass.

---

## 8 / Annex 1 : placement recommendations

## 8.1 > Main principles

VisionPass is designed to operate in most environmental conditions. Anyway, to optimize VisionPass performance, it is better to follow the rules below :

- Avoid sunlight coming directly on the device (for instance, avoid installing the device facing a window).
- Avoid direct sunlight on the user's face.
- Avoid strong left/right or top/bottom contrast, and shadows on the user's face due to lighting configuration.
- Prefer a neutral color background in the field-of-view of the product
- Avoid any bright spot light very close to the device (closer than 1 meter)
- Protect the front glass from raindrops as it might affect the sensors

If several devices are installed in parallel lanes (typically for gates or turnstiles), then a minimum distance of 80cm must be kept between the devices.

Alternately, devices can be tilted so that one device field of view does not interfere with the other one.

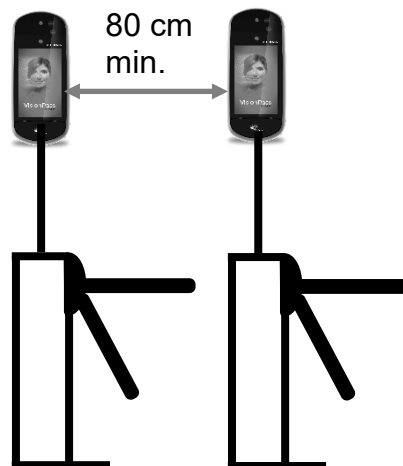

**Figure 35: Installation on turnstiles**

## 8.2 > Enrolment recommendations

To perform the best enrolment of the face of the users, please apply the following :

For the terminal :

- The terminal for enrolment must be installed in the same position as it is used : wall frame vertically fixed at a height of 1150mm from the ground.
- Avoid direct sunlight on the user's face and on the device
- Avoid bright spot light appear in the face area (no halo must appear which can lead to over exposure of the face image)

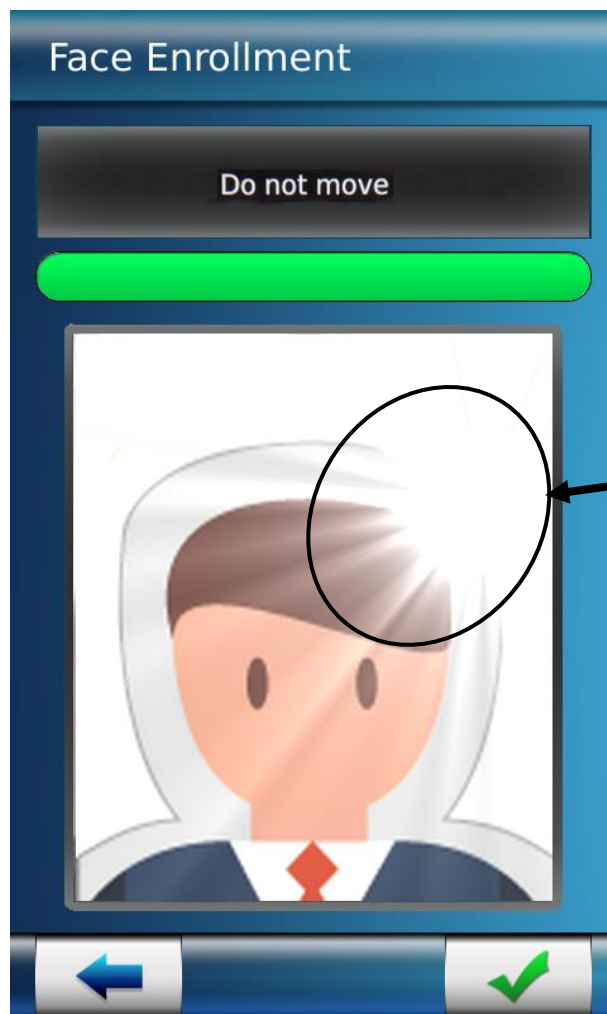

Halo created by a bright spot light facing the camera, behind the user.

For the user :

- Look at the device and do not move during the enrolment
- Keep a neutral expression (no smile)
- Remove all accessories from the face (no hat, no glasses, no scarf, etc.) : the face of the user has to be fully and clearly visible

---

## 9 / Annex 2 : Bibliography



## 9.1 > How to get the latest versions of documents

For the latest firmware, software, document releases, and news, please check our web site :

[www.biometric-terminals.com](http://www.biometric-terminals.com)

To get your log in and password please contact your sales representative.



## 9.2 > Documents about the MorphoWave Compact terminal

### *Documents about installing the terminal*

VisionPass Installation Guide,

Ref. 2019\_2000045728

This document describes terminal physical mounting procedure, electrical interfaces and connection procedures. This document is in English.

### *Documents about administrating / using the terminal*

VisionPass Quick User Guide,

Ref. 2019\_2000045730

This document gives a quick overview of the product and the basics of configuration and use. This document is in English.

Biometric terminals Administration Guide,

Ref. 2019\_2000036794

This document describes the different functions available on the terminal and procedures for configuring the terminal. It also contains the full description of all the configuration parameters for the terminal. This document is in English.

MWC - VisionPass Parameters Guide,

Ref. 2019\_2000035285

This document contains the full description of all the terminal configuration parameters. This document is in English.

### *Documents for the developer*

MorphoAccess 5G Series Host System Interface Specification,

Ref. 2019\_2000022602

This document describes the commands supported by the terminal. This document is in English.

MorphoAccess 5G Series Remote Message Specification,

Ref. 2019\_2000022373

This document describes the format of messages sent by the terminal to a distant system. This document is in English.

### *Release note*

For each firmware version, a release note is published describing the new features, the supported products, the potential known issues, the upgrade / downgrade limitations, the recommendations, the potential restrictions...

---

## 10 / Annex 3 : Support

## 10.1 > Troubleshooting

*The terminal IP address is unknown or it is not possible to connect to the terminal*

Use terminal interface to configure a valid set of network parameters in your terminal.

*The sensor is switched off*

Check that the database contains at least one record.

Check that the identification mode is enabled.

*The terminal returns erratic responses to Ping commands*

Check the subnet mask.

Ask the network administrator for the correct value.

Check that each device connected to the network has a different IP address.

## 10.2 > Technical Support and Hotline

*North America:*

Mail: [support.bioterminals.us@idemia.com](mailto:support.bioterminals.us@idemia.com)

Tel: +1 888 940 7477

*South America:*

Mail: [support.bioterminals.us@idemia.com](mailto:support.bioterminals.us@idemia.com)

Tel: +1 714 575 2973

*Europe, Middle East, Africa:*

Mail: [support.bioterminals@idemia.com](mailto:support.bioterminals@idemia.com)

Tel: +33 1 30 20 30 40

*Asia, Pacific:*

Mail: [support.bioterminals.in@idemia.com](mailto:support.bioterminals.in@idemia.com)

Tel: +91 1800 120 203 020

*Web site*

For the latest firmware, software, document releases, and news, please check our website :

[www.biometric-terminals.com](http://www.biometric-terminals.com)

To get your log in and password please contact your sales representative

