



LaserSense HSSD-2 Aspirating Smoke Detector Installers Handbook

Copyright

© 2021 Carrier. All rights reserved.

Contact information

For contact information, see firesecurityproducts.com.

European regulations for construction products

This section provides a summary on the declared performance according to the Construction Products Regulation (EU) 305/2011 and Delegated Regulations (EU) 157/2014 and (EU) 574/2014.

For detailed information, see the product Declaration of Performance (available at firesecurityproducts.com).

Certification	CE
Certification body	2831
Manufacturer	Carrier Manufacturing Poland Spółka Z o.o., Ul. Kolejowa 24, 39-100 Ropczyce, Poland. Authorized EU manufacturing representative: Carrier Fire & Security B.V., Kelvinstraat 7, 6003 DH Weert, Netherlands.
Year of first CE marking	19
Declaration of Performance number	
HSSD-2	360-3514-0199
HSSD-2 and command module	360-3514-0299
HSSD-2 and minimum display	360-3514-0399
EN 54	EN 54-20: 2006
Product identification	See model number on product identification label
Intended use	See the product Declaration of Performance
Declared performance	See the product Declaration of Performance

Content

	Important information	iii
	EN 54-20 and UL installation	vi
Chapter 1	Product and component descriptions	1
	Introduction	2
	Available software for the detector	2
	Specifications	3
	Standard detector	5
	Stand-alone command module or command module detector	7
	Standard detector interior view	8
	Stand-alone command module interior view	9
	Command module detector interior view	10
	Detector controls and indicators	11
	Display types	12
Chapter 2	Installation and assembly	13
	Introduction	14
	Antistatic precautions	14
	General installation guidelines	15
	System design	16
	Mechanical installation	18
	Electrical installation	21
	Power supply connections	27
	Demonstration mode	28
	Interfacing with fire alarm panels	29
	Connecting a command module to an addressable fire panel	32
	Connecting a single detector to an addressable fire panel	34
	Connecting to a PC	35
Chapter 3	Programming the unit	37
	Introduction	38
	Entering programming mode	38
	Main menu	39
	Navigating through the menus	40
	Detector programmable functions	41
Chapter 4	Commissioning	57
	Introduction	58
	Commissioning	58
	Precommissioning preparation	59
	Acclimation period	59
	Transport time verification	60
	Gross smoke testing	60

Chapter 5	Troubleshooting 61
	Troubleshooting the detector 62
	Error messages 64
Chapter 6	Maintenance 65
	Introduction 66
	Scheduled maintenance 66
	Maintenance procedures 67
Appendix A	External communications 71
	BMS protocols on the detector command module 72
	Paging from the command module 74
	Configuring the software 74
	Glossary 75
	Index 77

Important information

Regulatory information

This equipment is Class III as defined in EN 62368-1 (i.e., this equipment is designed to operate from Safety Extra Low Voltages and does not generate any hazardous voltages).

As this equipment is part of a fire detection system, input power should be supplied from an approved power supply conforming to EN 54-4 or UL/ULC and FM3230 standards.

In order for the installation to conform to EN 54-20, pipes must conform at least to EN 61386-1 Class 1131.

This product has been designed to meet the following requirements:

- NFPA 72 National Fire Alarm and Signaling Code
- UL 268 Smoke Detectors for Fire Alarm Signaling Systems
- UL 268A Smoke Detectors for Duct Applications
- UL 864 Control Units for Fire Protective Signaling Systems
- CAN/ULC-S524 Installation of Fire Alarm Systems
- ULC S527 Control Units for Fire Alarm Systems
- CAN/ULC-S529 Smoke Detectors for Fire Alarm Systems

System reacceptance test after reprogramming (UL/ULC and FM3230): To ensure proper system operation, this system must be retested in accordance with NFPA 72 after any programming change. Reacceptance testing is also required after any addition or deletion of system components, and after any modification, repair, or adjustment to system hardware or wiring.

Limitation of liability

To the maximum extent permitted by applicable law, in no event will Carrier be liable for any lost profits or business opportunities, loss of use, business interruption, loss of data, or any other indirect, special, incidental, or consequential damages under any theory of liability, whether based in contract, tort, negligence, product liability, or otherwise. Because some jurisdictions do not allow the exclusion or limitation of liability for consequential or incidental damages the preceding limitation may not apply to you. In any event the total liability of Carrier shall not exceed the purchase price of the product. The foregoing limitation will apply to the maximum extent permitted by applicable law, regardless of whether Carrier has been advised of the possibility of such damages and regardless of whether any remedy fails of its essential purpose.

Installation in accordance with this manual, applicable codes, and the instructions of the authority having jurisdiction is mandatory.

While every precaution has been taken during the preparation of this manual to ensure the accuracy of its contents, Carrier assumes no responsibility for errors or omissions.

Product warnings and disclaimers

THESE PRODUCTS ARE INTENDED FOR SALE TO AND INSTALLATION BY QUALIFIED PROFESSIONALS. CARRIER FIRE & SECURITY B.V. CANNOT PROVIDE ANY ASSURANCE THAT ANY PERSON OR ENTITY BUYING ITS PRODUCTS, INCLUDING ANY “AUTHORIZED DEALER” OR “AUTHORIZED RESELLER”, IS PROPERLY TRAINED OR EXPERIENCED TO CORRECTLY INSTALL FIRE AND SECURITY RELATED PRODUCTS.

For more information on warranty disclaimers and product safety information, please check <https://firesecurityproducts.com/policy/product-warning/> or scan the QR code:



Advisory messages

Advisory messages alert you to conditions or practices that can cause unwanted results. The advisory messages used in this document are shown and described below.

WARNING: Warning messages advise you of hazards that could result in injury or loss of life. They tell you which actions to take or to avoid in order to prevent the injury or loss of life.

Caution: Caution messages advise you of possible equipment damage. They tell you which actions to take or to avoid in order to prevent the damage.

Note: Note messages advise you of the possible loss of time or effort. They describe how to avoid the loss. Notes are also used to point out important information that you should read.

Product Symbols



This symbol appears on the main board of the unit and indicates that the board contains static sensitive components.



This label is located on the laser chamber at the bottom right of the open detector and signifies that the unit is a Class 1 Laser product as specified in IEC 60825-1. The unit incorporates a Class 3B embedded laser which must not be removed from the detector, as retinal damage may result if the laser beam enters the eye.



This symbol indicates the Safety ground studs. These are for grounding cable screens, etc., and should not be connected to 0V or signal earth.

EN 54-20 and UL installation

The pipe installation must be designed and verified for compliance with EN 54-20 using PipeCAD software. For more information on PipeCAD, see your PipeCAD documentation.

EN 54-20 installation

For EN 54-20 compliance the transport time of the last sampling hole shall be checked following all installation and proven to be less than or equal to that determined by PipeCAD.

The classification of each sampling device configuration and associated sensitivity settings are determined by the column headed Hole sensitivity % obs/m which shows the predicted sensitivity for each hole. For the installation to comply with EN 54-20 depending on the class of installation, each sampling hole must be no less sensitive than the following:

Class A: 0.62% obs/m

Class B: 1.95% obs/m

Class C: 4.65% obs/m

The calculation can be further refined by leaving a working detector in the protected area for at least 24 hours at the intended alarm factor for the installation (this could be done before or after installation). The detector sensitivity can be read from the “Sensitivity” figure on the histogram screen of the Remote software supplied with each detector.

The PipeCAD software will determine the classification of any used configuration. Commissioning and periodic system tests must involve smoke tests to verify that the system performs as expected and enters Alarm within the time determined by PipeCAD from the farthest hole. The detector sensitivity must also be inspected to ensure it has not radically fallen from the installed figure. If it has changed for any reason, the new figure must be re-entered into PipeCAD and the recalculated hole sensitivities must be confirmed to be within the class limits shown above.

The settings of a compliant system should be recorded, as it is possible by changing certain programmable functions to make the system non-compliant. If functions are changed, it is recommended that the system is retested if continuing compliance is in any doubt.

Note: For EN 54-20 compliant installations the detector requires that the flow thresholds be set manually to $\pm 6\%$ of the nominal value, after the FastLearn phase is completed. For example, if the flow rate is 64% after the completion of the FastLearn period, the user must manually set the low flow threshold to 58% and the high flow threshold to 70%.

UL installation

Note: UL certified products may also contain additional approvals, for example FM3230. Please refer to the product labels.

Chapter 1

Product and component descriptions

Summary

This chapter provides descriptions of the detector features, specifications, and controls and indicators.

Content

Introduction	2
Available software for the detector	2
Specifications	3
Standard detector	5
Stand-alone command module or command module detector	7
Standard detector interior view	8
Stand-alone command module interior view	9
Command module detector interior view	10
Detector controls and indicators	11
Display types	12

Introduction

The detector is a highly sophisticated “next generation” high sensitivity aspirating smoke detection product that provides all the benefits of air sampling high sensitivity smoke detection, including very early warning. Designed for easy installation and commissioning, the detector incorporates a patented “artificial intelligence” known as ClassiFire, which allows the detector to configure itself to optimum sensitivity, alarm thresholds, and minimum nuisance alarms for various environments.

The detector operates by drawing air from a protected space via a supervised piping network in relatively small areas. The sampled air is passed through a dust separator (filter) to remove dust and dirt before entering the laser detection chamber. State-of-the-art electronics are used to analyse the sampled air and generate a signal representing the level of smoke present.

ClassiFire intelligence also monitors the detector chamber, continually adjusting the appropriate operating parameters to counteract the negative effects of any contamination. Aspirating smoke detectors are unique in being able to provide a consistent level of protection in a very wide range of environments by continuously making minor adjustments to sensitivity.

Available software for the detector

The following software applications are available:

- **Remote:** Provided free of charge with every detector, this software package enables the user to set up and configure the programmable functions of one or more detectors or command module from a computer connected via an RS-232 serial cable.
- **SenseNET:** SenseNET software is used to configure and manage a large network of detectors with a simple, streamlined graphical user interface from a computer connected to a detector or command module via an RS-232 serial cable to RS-485 converter interface.

Specifications

Caution: This equipment is only to be used in accordance with this specification. Failure to operate the equipment as specified may cause damage to the unit, injury, or property damage.

Specification	Value
SELV rating	EN 62368-1 Class III
Supply voltage	21.6 to 26.4 VDC PSU Type: conforming to EN 54-4.
Size (W × H × D)	427 × 372 × 95 mm (16.8 × 14.6 × 3.7 in.)
Weight	
Detector	5.2 kg (11.5 lb.)
Command module detector	5.3 kg (11.6 lb.)
Stand-alone command module	6.2 kg (13.6 lb.)
Stand-alone command module and batteries	10.1 kg (22.3 lb.)
Operating temperature range	-10 to +60°C (EN 54-20) 32 to 100°F (0 to 38°C) (UL 268, CAN/ULC-S529, FM3230)
Operating humidity range	0 to 90% noncondensing EN 61010-1 Pollution degree 1 EN 61010-1 Installation Cat. II
Sensitivity range	
(%obs/m)	Min. = 25%, Max. = 0.03% FSD
(%obs/ft.)	Min. = 7.62%, Max. = 0.00914% FSD
Maximum sensitivity resolution	0.0015% obs/m (0.00046% obs/ft.)
Detection principle	Laser light scattering mass detection
Particle sensitivity range	0.0003 to 10 microns
Current consumption	
Detector	300 mA (fan speed 1) 470 mA (fan speed 8) 750 mA (fan speed 16)
Stand-alone command module	450 mA
Command module detector	750 mA (fan speed 1) 920 mA (fan speed 8) 1.5 A (fan speed 16)
Relay contact rating	500 mA at 30 VDC
Maximum sampling pipe length	200 m (656 ft. total)
Sampling pipe inlets	4
Maximum number of sampling holes	25 per pipe (100 total)
Sampling pipe internal diameter	3/4 in. (ID) or 27 mm (OD)
Alarm levels	4 (Alarm 2, Alarm, Pre-Alarm, and Aux. Alarm)
Bar graph sensitivity range	0.0015 to 25% obs/m (0.00046 to 7.62 obs/ft.)
Bar graph segments	26

Specification	Value
Chamber service intervals	Greater than 8 years (depending on environment)
Dust separator (filter) replacement intervals	Greater than 5 years (depending on environment)
Laser lifetime (MTTF)	Greater than 50 years
Programming	Front panel or PC via RS-232/RS-485
Data bus cable	RS-485 data cable
Data bus length	1,200 m (4,000 ft.)
IP rating	IP40

Standard detector

The standard detector may be operated as a stand-alone unit, or may be part of a network of detectors centrally monitored by a command module. It may be programmed via its front panel, as in the standard detector and command module versions, shown in Figure 2 on page 6 and Figure 3 on page 7.

Alternatively, the standard detector can be ordered without a front panel display (minimum display) as shown in Figure 1 below. The detectors may be programmed remotely via the detector's RS-485 terminals using a command module, or via the detector's RS-232 port using a PC running the Remote software. A copy of this software is supplied with each detector.

The standard detector without a front panel display is housed in a rugged sheet metal steel enclosure. This detector includes LEDs to indicate alarms, faults, and normal operating conditions. The standard detector with display (and command module) can also be ordered with the steel enclosure.

Figure 1: Minimum display detector

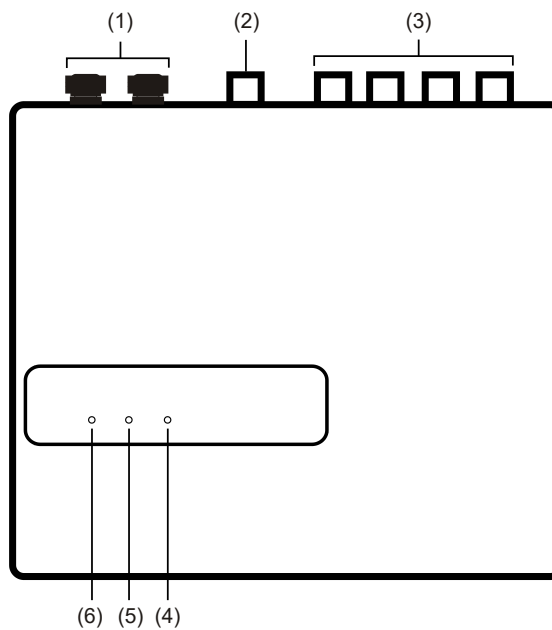

- | | |
|--|--|
| (1) Cable glands | (5) Fault LED: Illuminates when the unit has a fault and a fault signal is being sent to the fire alarm panel. It also illuminates when the unit is isolated. |
| (2) Exhaust port | |
| (3) Sampling ports | |
| (4) Alarm LED: Illuminates when the alarm level has been reached and the appropriate time delays have expired. | (6) OK LED: Illuminates to show normal operation when there are no faults. The OK lamp will flash during the 15-minute FastLearn period when the detector is first learning about its environment. |

Figure 2: Standard detector

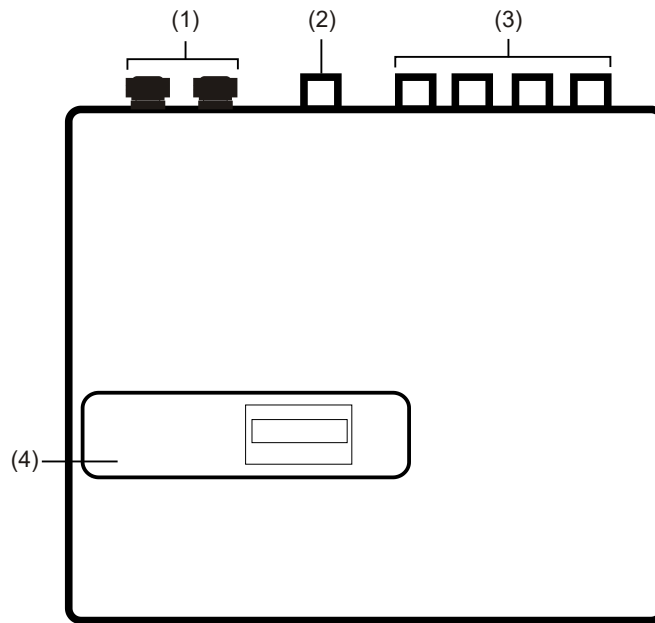

- (1) Cable glands
- (2) Exhaust port

- (3) Sampling ports
- (4) Front panel display

Stand-alone command module or command module detector

When multiple detectors are networked together, a command module may be used to tie all the detectors together and to provide a centralized point for network access and programming, running diagnostics, and PC and fire panel connection.

The command module can be mounted either inside a detector or as a stand-alone unit in its own housing without an aspirator or smoke detection circuitry. If detectors attached to the command module are mounted in different fire zones then the command module must be mounted in its own housing with separate power supply to comply with BS 5839 and EN 54.

When a command module is mounted inside a detector, the standard detector display is replaced with a dedicated command module display. The programming buttons and display on the front of the detector belong to the command module.

Programming at the command module is very similar to programming a detector, the main difference being that the command module has extra functions to control all the aspirating detectors connected in the network.

Figure 3: Command module detector

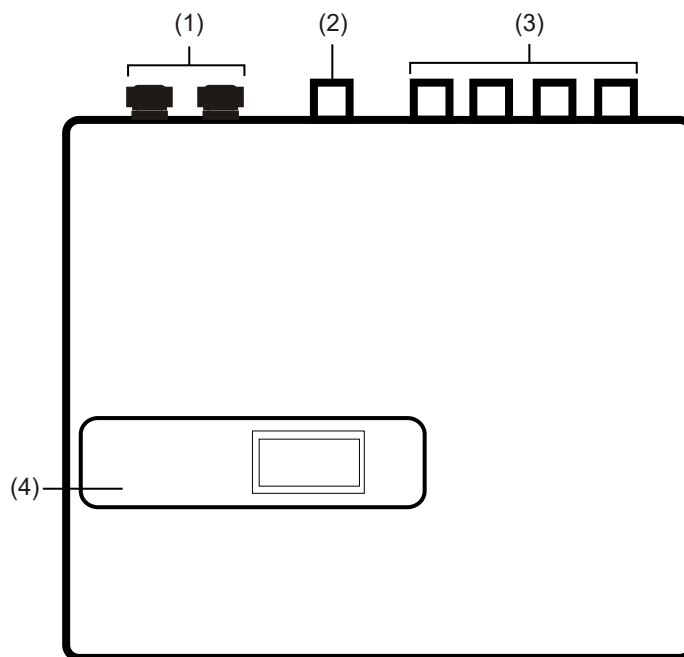

(1) Cable glands

(2) Exhaust port

(3) Sampling ports

(4) Front panel display

Standard detector interior view

Figure 4: Standard detector interior view

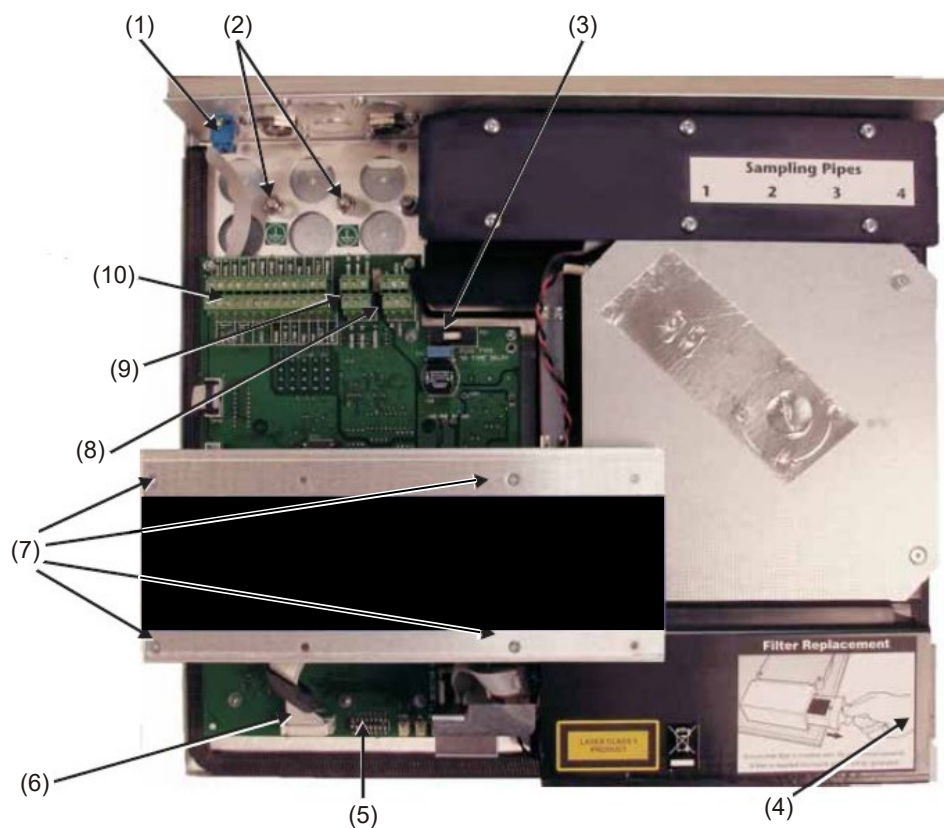

(1) RS-232 serial port

(2) Safety earth studs

(3) 1 A, 5 x 20 mm T-type protection fuse

(4) Dust separator (filter) removal handle

(5) Detector address DIP switch

(6) Front panel display connectors

(7) Display attachment screws

(8) 24 VDC power supply connections

(9) RS-485 terminal connections

(10) Terminal block connections

Stand-alone command module interior view

Figure 5: Stand-alone command module interior view

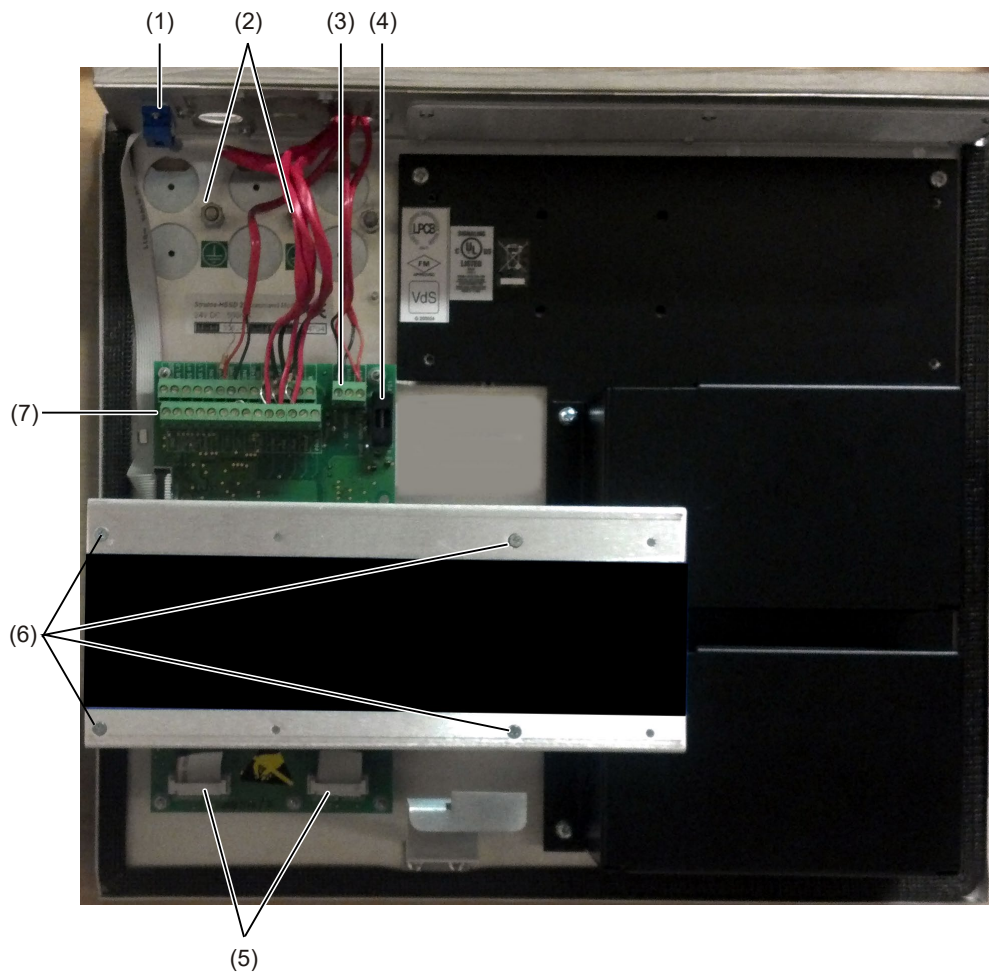

- | | |
|--|------------------------------------|
| (1) RS-232 serial port | (5) Front panel display connectors |
| (2) Safety earth studs | (6) Display attachment screws |
| (3) 24 VDC power supply connections | (7) Terminal block connections |
| (4) 500 mA, 5 x 20 mm T-type protection fuse | |

Command module detector interior view

Figure 6: Command module detector interior view

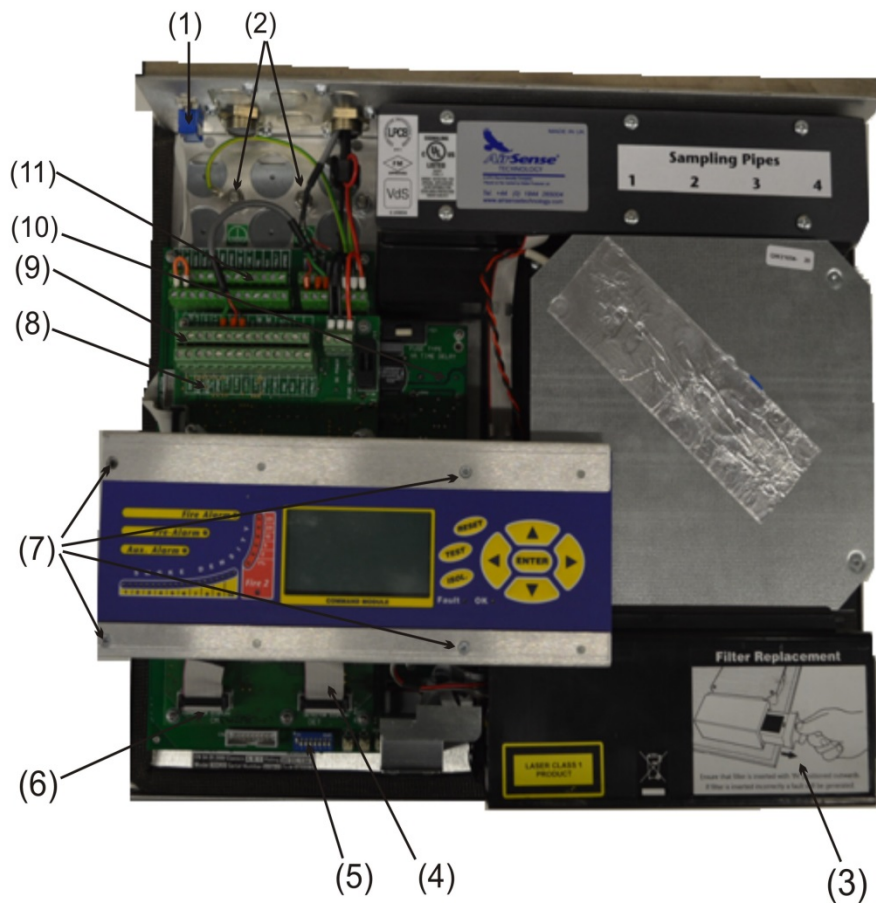

- (1) RS-232 serial port
- (2) Safety earth studs
- (3) Dust separator (filter) removal handle
- (4) Detector display connection
- (5) Detector address DIP switches
- (6) Command module display connection
- (7) Display attachment screws
- (8) Command module CPU board
- (9) Command module CPU board - terminal block connections
- (10) Detector CPU board
- (11) Detector CPU board - terminal block connections

Detector controls and indicators

The standard detector and the command module detector controls and indicators are very similar.

Figure 7: Standard detector

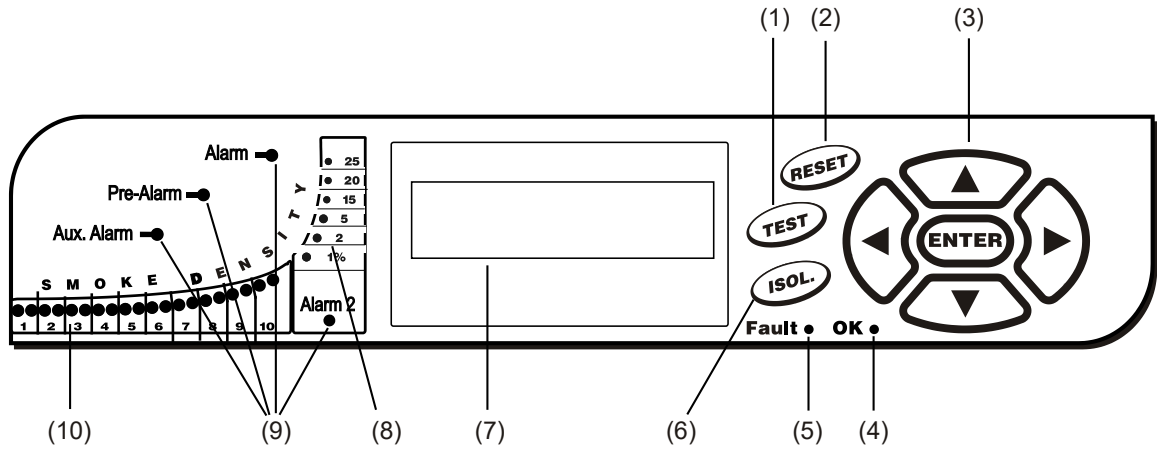
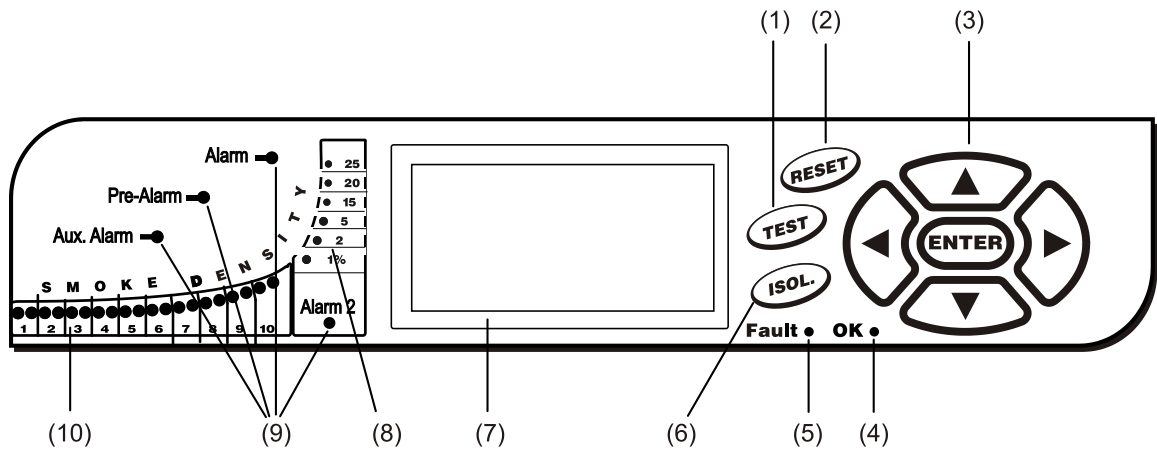

Figure 8: Command module detector



- (1) The <TEST> Button starts a lamp test which makes the detector show its nominal operating sensitivity as calculated by the ClassiFire artificial intelligence System.
- (2) The <RESET> Button clears any latched alarms or faults and sets the status display back to its normal operation display. To comply with national standards, detectors are supplied with the RESET function disabled as the default.
- (3) MENU Buttons are used when programming the unit, which is password-protected. See “Navigating through the menus” on page 40, for more information. Pressing the UP or DOWN arrow keys when not in programming mode (the access code has not been entered) scrolls through the detector’s event log. Refer to “Event log” on page 54 for more information
- (4) The OK Indicator illuminates to show normal operation when there are no faults. On the command module, this means that the command module and all detectors on the loop are operating normally.
- (5) The Fault Indicator illuminates when the unit has a fault and a fault signal is being sent to the fire alarm panel. On the command module, this also indicates a fault in a detector on the communications loop, or in the loop itself.

- (6) The <ISOL> Button toggles the unit's isolation state. When isolated, the unit cannot generate any alarms and will signal a fault condition and the text display will show Panel Isolate. A detector is shipped with its <ISOL> Button disabled as default. These three buttons can be individually enabled or disabled. The factory default state of the detector is: <TEST> button enabled and <RESET> and <ISOL> buttons disabled.
- (7) Status Display (if fitted) shows all events as they happen in real time and is also used to configure the unit.
- (8) Smoke Density Indicators (scaled smoke levels) display absolutely scaled smoke levels above 1% obscuration per metre (0.30% obscuration per foot) to a maximum of 25% obs/m (7.62% per foot). The Alarm 2 activation level is programmed normally somewhere in this range. The bar graph display will show a continually cycling pattern when the unit is in FastLearn mode. On the command module display, this will occur when any unit on the RS-485 communications loop is in FastLearn. Otherwise, the bar graph display on the command module mimics the bar graph display on the highest-reading detector on the loop.
- (9) Aux. Alarm, Pre-Alarm, Alarm, and Alarm 2 indicators illuminate when the set alarm level has been reached and the set time delays have expired. On a command module, the indicators signify an alarm condition from any detector on the communications loop.
- (10) Smoke Density Indicators (1 through 10) are the relatively scaled ClassiFire bar graph and changes in steps of half a segment.

Display types

The standard detector display is a two-line LCD which allows basic programming of the detector. See Figure 9.

Figure 9: Standard detector display

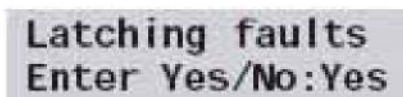

Latching faults
Enter Yes/No:Yes

The command module display contains more information than the standard detector display. The command module display instructs the user with graphic symbols. See Figure 10.

Figure 10: Command module display

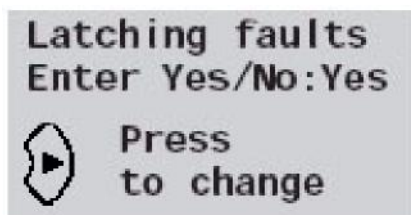

Latching faults
Enter Yes/No:Yes
 Press
to change

Chapter 2

Installation and assembly

Summary

This chapter provides information necessary to install and configure the detector system.

Content

Introduction	14
Antistatic precautions	14
General installation guidelines	15
System design	16
Mechanical installation	18
Removing and replacing the front cover	20
Electrical installation	21
Detector terminal block connections	22
Command module terminal block connections	24
Relay connections	25
Connecting power cables	26
Power supply connections	27
Demonstration mode	28
Interfacing with fire alarm panels	29
Setting the detector address	29
Connecting a detector network to a command module	31
Fault tolerant detector loop configuration	31
Non-fault tolerant serial configuration	31
Connecting a command module to an addressable fire panel	32
Connecting a single detector to an addressable fire panel	34
Connecting to a PC	35

Introduction

This chapter provides information necessary to install the detector system.

To install the detector:

1. Unpack the shipping carton. Ensure that the package contains a CD-ROM, two ferrite rings, two keys, two cable glands, and the unit.
2. Determine the optimum location for the detector.
3. Do not open any unused sampling pipe inlets. Remove the inlet caps from sampling pipe inlets to be used.
4. Remove the knockouts for field wiring and battery connections.
5. Mount the wall-mounting bracket.
6. Mount the detector to the mounting bracket.
7. Connect the detector to the sampling pipe network.
8. Connect field wiring to the detector.
9. Power up and program the detector.

Installation should only be done by trained technicians.

Installation should be in accordance with applicable installation requirements.

These include:

- NFPA-70, National Electrical Code
- NFPA-72, National Fire Alarm and Signaling Code
- CSA C22.1 Canadian Electrical Code, Part 1
- CAN/ULC-S524 Installation of Fire Alarm Systems
- Any other local, national, or installation requirements or standards.

WARNING: Electrocution hazard. All connections should be made with the power turned off.

Antistatic precautions

This system contains static-sensitive components. Always ground yourself with a proper wrist strap before handling any circuits. This recommendation must be followed when removing the equipment case, and during installing and servicing.

Caution: When handling any electric components or printed circuit boards, antistatic precautions must be followed. Failure to do so may result in component damage.

Static discharge can be reduced by adhering to the following guidelines:

- Always use conductive or antistatic containers for transportation and storage, if returning any item.
- Wear a wrist strap while handling devices and ensure that a good ground is maintained throughout the installation process.
- Never subject a static sensitive device to sliding movement over an ungrounded surface and avoid any direct contact with the pins or connections.
- Avoid placing sensitive devices onto plastic or vinyl surfaces.
- Minimise the handling of sensitive devices and Printed Circuit Boards (PCBs).

General installation guidelines

The following is a brief set of guidelines on installing detectors:

- It is recommended that system design and installation is carried out by suitably experienced and trained personnel.
- The detector should normally be mounted at a level where there is easy access to the unit for configuration and programming.
- Unused sampling pipe inlets must be left closed.
- The exhaust air from the unit must not be impeded in any way. If the unit is mounted in a different air pressure from where the air is being sampled (for example an air duct), then a pipe must be routed from the exhaust port back to the same air pressure zone as the sampling holes.
- All signal cables must be screened and must be of a suitable type. The specific type of cable will normally depend on the local fire regulations.
- The unit must not be placed in areas where either the temperature or humidity is outside the specified operating range.
- The unit should not be placed in close proximity to any equipment expected to generate high radio frequency levels (such as radio alarms) or units generating high levels of electrical energy (such as large electric motors or generators).
- Ensure that when the detector is fitted to the wall there is enough space on the right-hand side to allow removal and replacement of the filter element.

Table 1 contains a list of procedural guidelines for installation of the detector.

Table 1: Procedural guidelines

Do	Don't
Ensure that the power and signal cables are correctly connected before powering up by use of cable identifiers or electrical continuity checks. Incorrect connection could damage the detector.	Drop the detector.
Ensure that cable of an appropriate approved type is used for interconnection.	Install detectors in damp or exposed areas.
Ensure that all screws for wiring connections are firmly tightened.	Remove or connect boards when the detector is powered up.
Place sampling points so that the detector will be able to detect smoke at the earliest opportunity.	Connect internal 0 volt terminals to local earth.
Ensure that the detector exhaust is in an area with the same atmospheric pressure as the sample pipes, either by placing the detector physically in the protected area or by leading a pipe from the detector exhaust to the protected area.	Attempt to re-use dust filter cartridges once removed.
Ensure that the environment of the protected area is within the environmental operating parameters of the detector.	Attempt to adjust or alter detector settings other than via the user-programmable functions. Any attempts to adjust the laser potentiometer are detectable and will void the warranty on the product.
Close unused pipe inlet ports on the detector to ensure optimal operation.	Place the detector near high power RF sources.
Set the appropriate ClassiFire alarm factor for the area to be detected.	Place the detector so close to other equipment that there is insufficient room to access and change the dust separator.
Set the detector address switches correctly when used in a network.	Use sampling pipe of less than 1 inch (27 mm) outside diameter without a suitable 1 inch (27 mm) pipe adapter. It is important that there are no leaks where the pipe connects to the detector.
	Use excessive force when fitting sampling pipes as this may damage the detector.

System design

Aspirating system design is inherently simple. It is often possible to achieve good system performance with very simple installations. There are however a few rules which must be adhered to, and these rules are equally applicable to all aspirating systems which operate on similar principles to this detector. The information contained in this handbook is intended as an overview only.

Do not expect one detector to achieve good performance if sampling from areas of different air pressure (typically: under floor air plenums and room spaces or different rooms in air-conditioned areas). This is because the air pressure differences may cause reverse or poor airflow along the sampling pipes. If it is not possible to locate the detector within the protected area it may be necessary to lead an exhaust pipe from the detector exhaust port returning air to the protected area. See Figure 11 on page 17.

Always locate the sampling points in a position to which smoke may reasonably be expected to travel. This may sound obvious, but, for example, do not expect ceiling mounted sampling points to operate satisfactorily if air flow prevents the

cool smoke from an incipient fire from reaching ceiling level. In this instance it is usually better to locate the sampling pipes directly in the airflow (for example in an air conditioning unit air intake). There is no substitute for carrying out smoke tests prior to installation of pipes to indicate suitable sampling point location.

Note: PipeCAD pipe modeling software must be used when designing a pipe network and verifying its performance.

Figure 11: Locating the detector outside the protected area

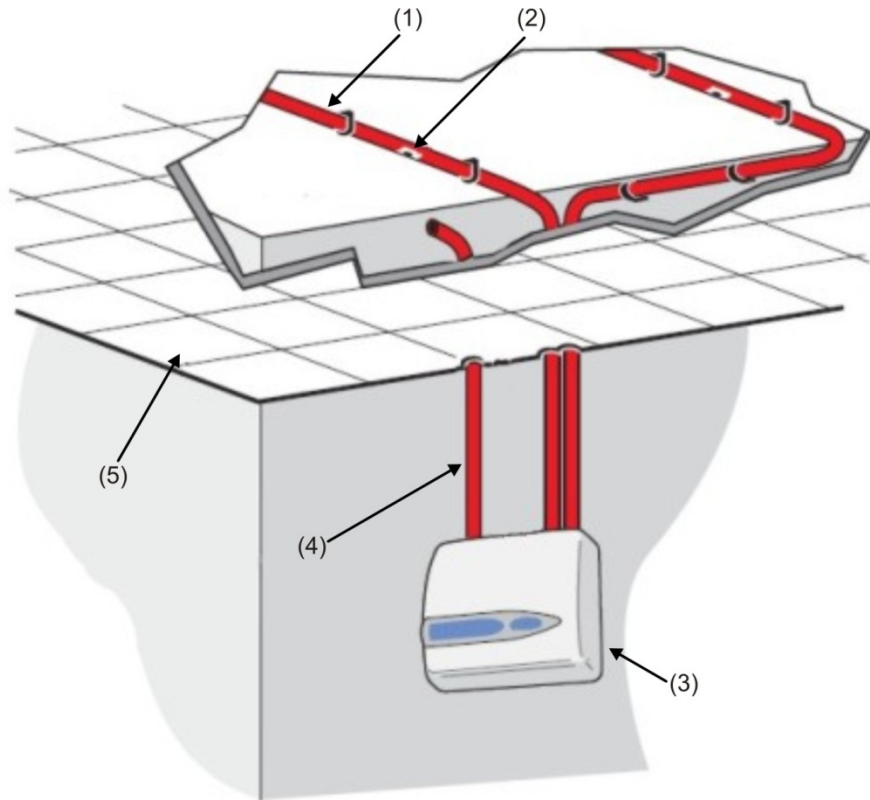

- (1) Sampling pipe
- (2) Sampling hole
- (3) Detector
- (4) Exhaust pipe
- (5) False ceiling

Pipework

Sampling pipes should be made from a non-hazardous material and should be clearly identified. The ideal internal diameter of sampling pipes is 22 mm (0.87 in.). Other sizes will often work but will provide different response times.

Ideally, if the total length of sampling pipe is greater than 50 m (164 ft.), then multiple pipes should be used. When using multiple sampling pipes, care should be taken to achieve a reasonable degree of balance (say within 10% of airflow) to ensure even suction from the pipes.

Maximum recommended total sampling pipe length is 200 m (656 ft.). This is 4 lengths of 50 m (164 ft.), or 2 lengths of 100 m (328 ft.).

In order for the installation to conform to EN 54-20, pipes must conform at least to EN 61386-1 Class 1131.

Sampling pipes must have capped ends. The end cap should be drilled with a sampling hole normally between 4 or 5 mm (0.16 or 0.20 in.) diameter and free from burrs. Sampling holes should normally be 3 to 4 mm (0.12 or 0.16 in.) diameter or as calculated by PipeCAD and free from burrs. Each pipe run should not have more than 25 holes.

Pipe transit time must not exceed 120 seconds and an approved type of pipe must be used for installations. When drilling holes in the sample pipes, or cutting off lengths of pipe, ensure that all swarf and debris is removed from the pipe. This guide holds true for average sampling pipe lengths, but if using long pipes (typically more than 60 m/197 ft. total), performance may be improved by making the sampling holes near the ends slightly larger than those nearer the detector.

Use of PipeCAD software

PipeCAD pipe modeling software must be used when designing a pipe network and verifying its performance. For more information on PipeCAD, see your PipeCAD documentation.

Mechanical installation

Before installing the detector the local standards for installation of aspirating detection systems must be consulted as these standards differ throughout the world. Specific advice for one country may not be applicable to another.

The detector body is fitted to a wall-mounting bracket which is attached to the wall via three mounting holes E as shown in Figure 12 on page 19. The detector is then fitted over the mounting stud D and secured inside the detector body with the nut provided for the purpose.

For a more discreet layout, it is possible to allow the sampling pipes and cables to enter the detector from the rear, with the sample pipes and connection cables channeled into the wall. Figure 11 on page 17 depicts the detector with cables channeled into the wall and the sampling pipes not channeled into the wall.) In order to achieve this, sampling holes A and B need to be opened up to a diameter of 30 mm (1.25 in) to take the sampling pipes A and the exhaust pipe B. The holes C need to be opened up to 25 mm (1.0 in.) diameter in order to take a suitable threaded metal cable gland to provide adequate RF screening for the connection cables. These modifications are shown in dotted lines in Figure 12.

The wall will also need to be suitably prepared to allow the mounting plate to sit flush against the wall. The sampling and exhaust pipes must also extend out of the wall sufficiently to tightly engage in the pipe entry points on the rear of the detector (as shown in Figure 12). If the detector does not fit flush with the mounting bracket, the pipe excess should be trimmed back in small increments until the correct fit is achieved.

Figure 12: Detector installation options

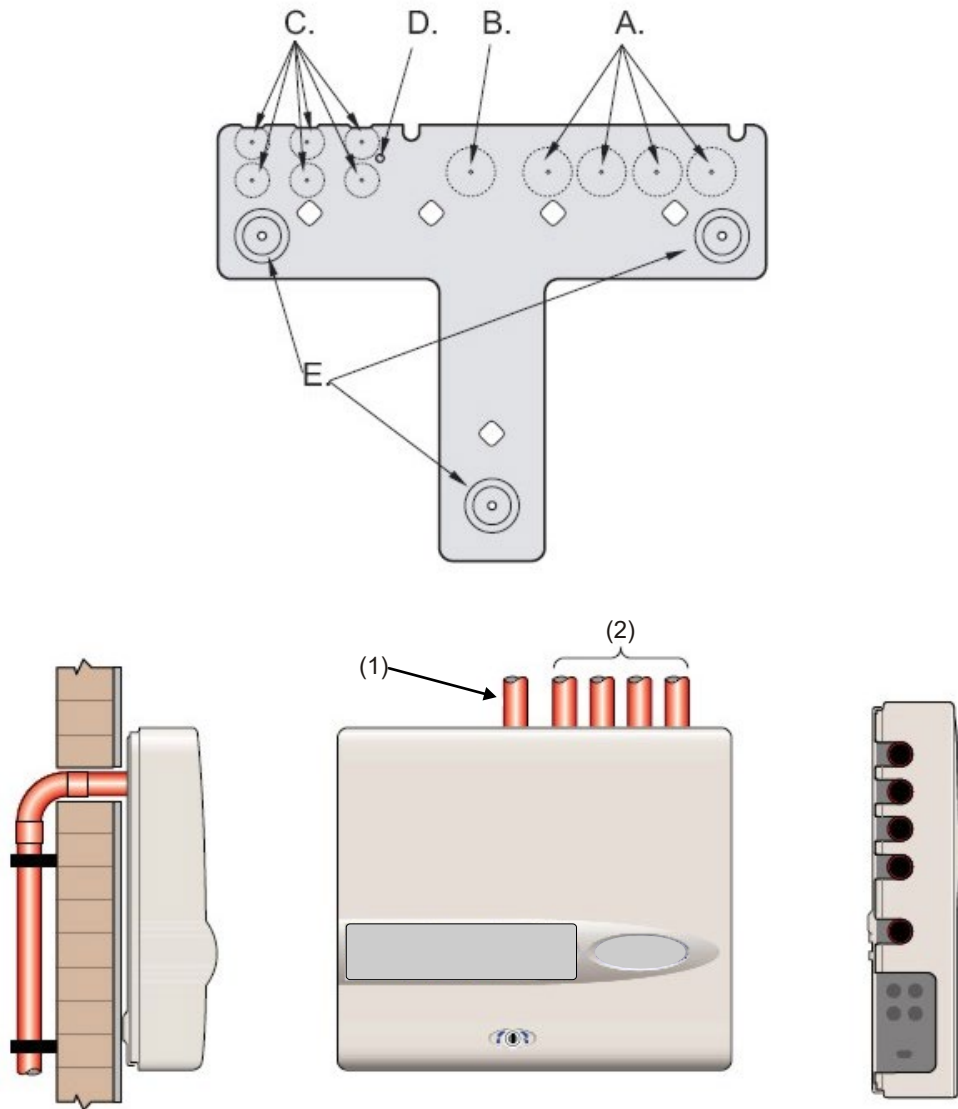

- (1) Exhaust pipe
- (2) Sampling pipes

Removing and replacing the front cover

To remove the front cover, unlock it using the key provided (turn counter-clockwise). The bottom of the front cover may then be lifted away from the detector chassis until the top of the cover disengages from the retaining rails at the top of the chassis. The cover may then be removed.

If greater internal access is required, e.g., for software upgrades, it may be necessary to remove the front panel display. To do this, use an anti-static wrist strap to prevent possible static damage to the unit's electronics and proceed as follows.

To remove the display:

1. Power down the unit.
2. Unfasten the four counter-sunk crosshead screws holding the display to the display mounting brackets.
3. Lift the display away from the main board.

Note: It is not necessary to remove the remaining four screws.

If the display needs to be completely removed, unplug the display ribbon connectors from the detector or command module main board, taking note of the position of the connectors which are as follows:

- For the standard detector, a single ribbon cable connected to the detector's front panel display connector.
- For the command module Detector, a twin ribbon cable, one ribbon connected to the detector's front panel" display connector and marked "DISPLAY DET," and one connected to the command module board's Commander Display connector and marked "COMMAND CM."
- For the Stand-Alone command module, a twin ribbon cable, one ribbon connected to the detector display connector and marked "COMMAND DET," and one connected to the Commander Display connector and marked "COMMAND CM."

When the display needs to be completely removed, disengage the ribbon connectors from the main detector or command module board and NOT from the display board.

Refitting of the display is the reverse of the above. Ensure that the connectors are refitted as described above. To refit the front cover, hook the recessed lip at the top of the front cover behind the two retaining guard rails at the top of the chassis as shown in Figure 13 on page 21.

Figure 13: Hooking the recessed lip at the top of the front cover

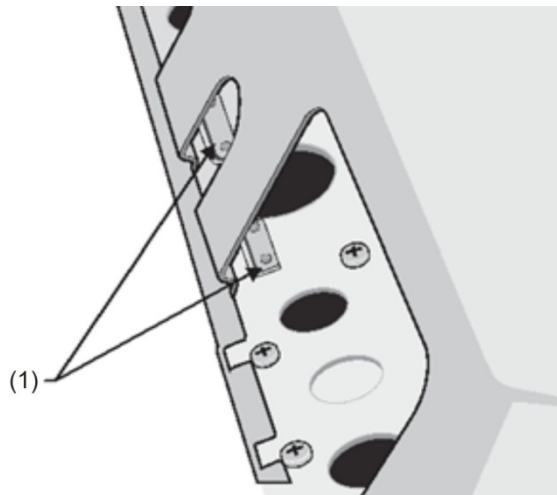

(1) Guard rails

Electrical installation

All electrical (power and signal) connections should be made to the green power terminal block inside the detector. Power cables should have sufficient current-carrying capacity. Refer to “Specifications” on page 3 for current consumption. Signal cable should be 120 volt shielded (screened) twisted pair such as Belden 9841 24 AWG. Power and signal cables should enter the detector via metal cable glands.

Detector terminal block connections

Figure 14 below shows the terminal block connections for a standard detector.

Figure 14: Detector terminal block connections

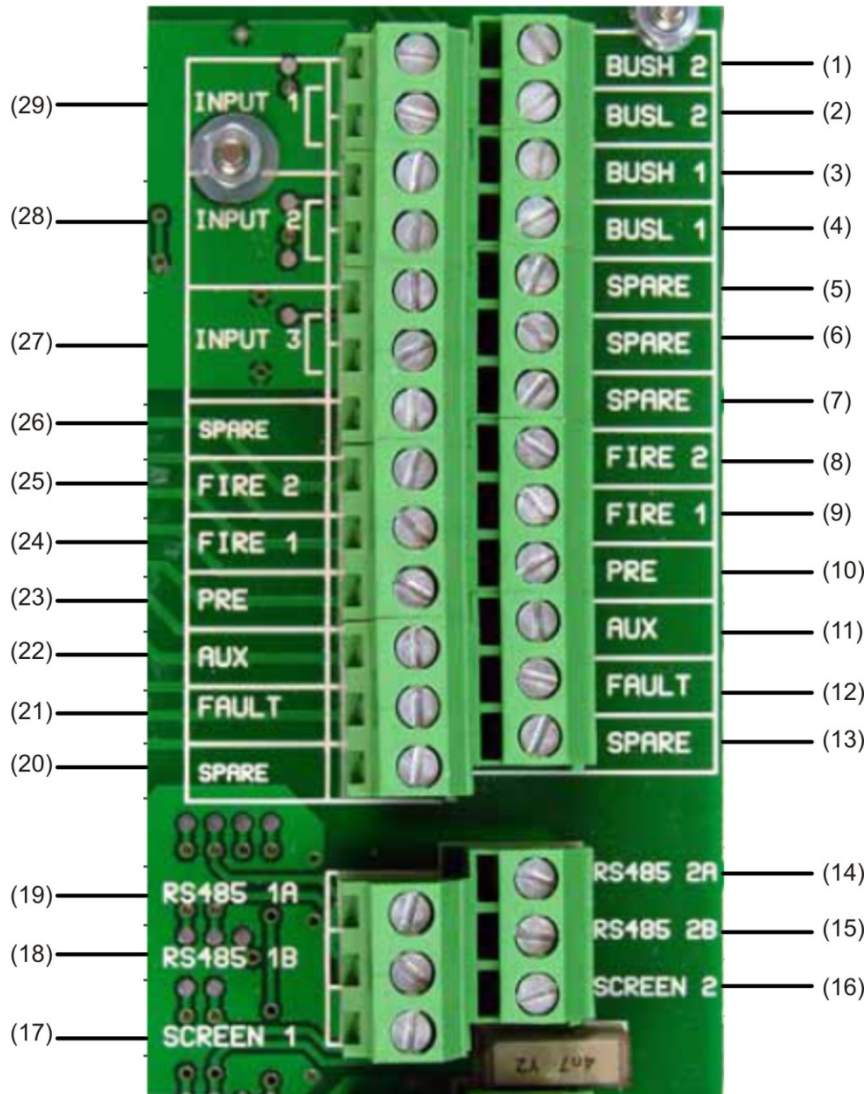

Item	Name	Description
(1)	BUSH 2	Addressable bus 2 high o/p [2]
(2)	BUSL 2	Addressable bus 2 low o/p [2]
(3)	BUSH 1	Addressable bus 1 high o/p [2]
(4)	BUSL 1	Addressable bus 1 low o/p [2]
(5)	SPARE	Spare
(6)	SPARE	Spare
(7)	SPARE	Spare
(8)	FIRE 2	N/O Fire 2 contacts
(9)	FIRE 1	N/O Fire 1 contacts

Item	Name	Description
(10)	PRE	N/O Pre-Alarm contacts
(11)	AUX	N/O Aux contacts
(12)	FAULT	N/C Fault contacts
(13)	SPARE	Spare
(14)	RS-485 2A	RS-485 bus 2 data line A
(15)	RS-485 2B	RS-485 bus 2 data line B
(16)	SCREEN 2	RS-485 bus 2 screen
(17)	SCREEN 1	RS-485 bus 1 screen
(18)	RS-485 1B	RS-485 bus 1 data line B
(19)	RS-485 1A	RS-485 bus 1 data line A
(20)	SPARE	Spare
(21)	FAULT	N/C Fault contacts
(22)	AUX	N/O Aux contacts
(23)	PRE	N/O Pre-Alarm contacts
(24)	FIRE 1	N/O Fire 1 contacts
(25)	FIRE 2	N/O Fire 2 contacts
(26)	SPARE	Spare
(27)	INPUT 3	Remote input 3. Short pair to activate [1]
(28)	INPUT 2	Remote input 2. Short pair to activate [1]
(29)	INPUT 1	Remote input 1. Short pair to activate [1]

N/O = Normally Open

N/C = Normally Closed

[1] These connections can be used as the input terminals for main supply and battery fault sensing. When this is the case, the contacts will signal a fault when the contacts are open rather than closed, as fault relays operate in the opposite sense to other relays, i.e., they are open for normal operation. The factory default setting is for supply monitoring on "I/P 1." If Input 1 is not being used for power supply monitoring, make sure that the Battery check function in the Remote software is not checked (off) for EN 54-20 compliance. The Battery check function is located in the Function settings menu, Power monitoring tab.

[2] These connections are used to connect a detector to an addressable fire panel when a suitable Addressable Protocol Interface Card is mounted to the "Addressable Interface" connector on the left-hand edge of the detector main PCB. (Refer to "Interfacing with fire alarm panels" on page 29 for more information on APIC cards.)

Command module terminal block connections

All electrical (power and signal) connections should be made to the green terminal block inside the detector. Power cables should be shielded (screened) and of sufficient current-carrying capacity. Signal cable should be 120 volt screened twisted pair such as Belden 9841 24 AWG. Power and signal cables should enter the detector via metal cable glands.

Figure 15 below shows the terminal block connections for the command module.

Figure 15: Command module terminal block connections

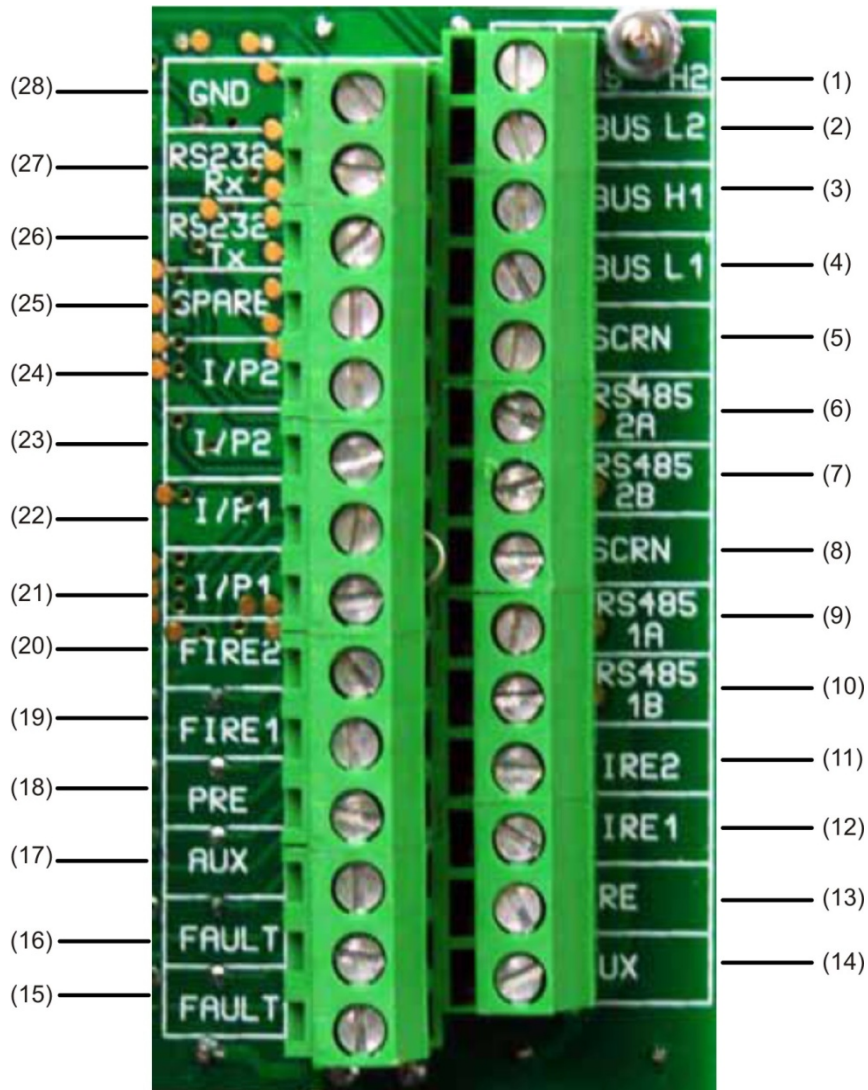

Item	Name	Description
(1)	BUS H2	Addressable bus 2 high o/p [2]
(2)	BUS L2	Addressable bus 2 low o/p [2]
(3)	BUS H1	Addressable bus 1 high o/p [2]
(4)	BUS L1	Addressable bus 1 low o/p [2]
(5)	SCRN	RS-485 bus 1 screen
(6)	RS-485 2A	RS-485 bus 2 data line A

Item	Name	Description
(7)	RS-485 2B	RS-485 bus 2 data line B
(8)	SCRN	RS-485 bus 2 screen
(9)	RS-485 1A	RS-485 bus 1 data line A
(10)	RS-485 1B	RS-485 bus 1 data line B
(11)	FIRE2	N/O Fire 2 contacts
(12)	FIRE1	N/O Fire 1 contacts
(13)	PRE	N/O Pre-Alarm contacts
(14)	AUX	N/O Aux contacts
(15)	FAULT	N/C Fault contacts
(16)	FAULT	N/C Fault contacts
(17)	AUX	N/O Aux contacts
(18)	PRE	N/O Pre-Alarm contacts
(19)	FIRE 1	N/O Fire 1 contacts
(20)	FIRE 2	N/O Fire 2 contacts
(21)	I/P1	Remote input 1, Short pair to activate [1]
(22)	I/P1	Remote input 1, Short pair to activate [1]
(23)	I/P2	Remote input 2, Short pair to activate [1]
(24)	I/P2	Remote input 2, Short pair to activate [1]
(25)	SPARE	Spare connection
(26)	RS-232 Tx	RS-232-2 transmit line
(27)	RS-232 Rx	RS-232-2 receive line
(28)	GND	RS-232-2 earth

N/O = Normally Open

N/C = Normally Closed

[1] These connections can be used as the input terminals for main supply and battery fault sensing. When this is the case, the contacts will signal a fault when the contacts are open rather than closed, as fault relays operate in the opposite sense to other relays, i.e., they are open for normal operation. The factory default setting is for supply monitoring on "I/P 1."

[2] These connections are used to connect a command module to an addressable fire panel when a suitable Addressable Protocol Interface Card is mounted to the "Addressable Interface" connector on the left hand edge of the command module main PCB. (Refer to "Interfacing with fire alarm panels" on page 29 for more information on APIC cards.)

Relay connections

Connect the screen of the relay cables to the earth stud of the detector.

Connecting power cables

The following precautions should be taken only for those applications where the system is required to meet EMC compliance requirements:

- Screened power cable should be used.
- The earth wire of power cables should be connected to the detector EARTH terminal and this, in turn, connected to a ground stud on the detector chassis.
- All cables (power and signal) should pass through the screw-in metal cable glands provided. The screen of the power cable should be terminated at the cable gland.
- Power cables need to be fitted with a ferrite ring inside the detector case (two are provided). The 24V and 0V wires should be long enough to form a loop around the ferrite wall.
- Separate wires from the power cables should be kept as short as possible, just enough to provide adequate stress relief.

Figure 16 and Figure 17 show the proper arrangement of top and rear entry power cables.

Figure 16: Top power cable arrangement

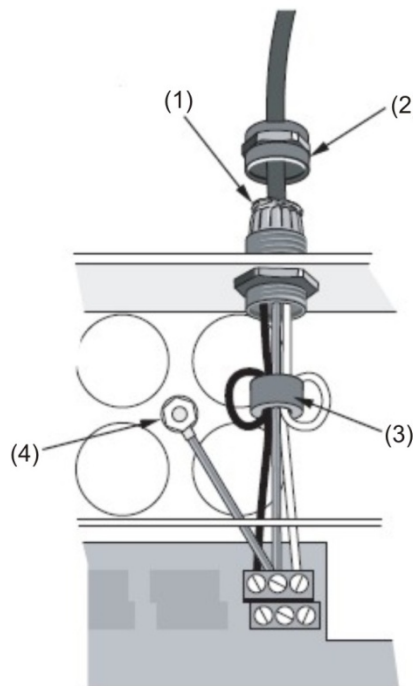

(1) Cable screen

(2) Cable gland

(3) Ferrite

(4) Earth stud

Figure 17: Rear power cable arrangement

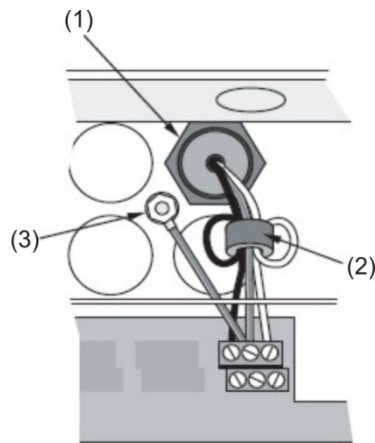

(1) Cable gland

(3) Earth stud

(2) Ferrite

Power supply connections

The detector may be powered by any EN 54-4 or UL/ULC and FM3230 compliant monitored 24 VDC power supply of sufficient capacity. (See Figure 18.)

Figure 18: Detector power supply connections

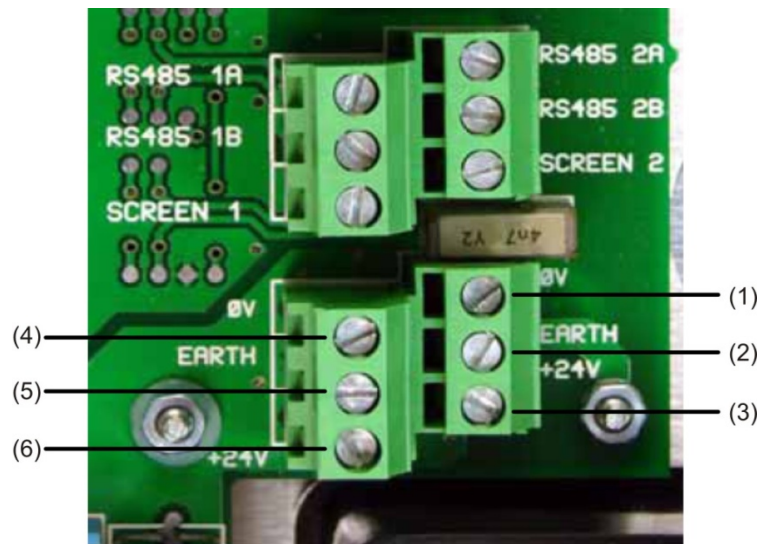

(1) 0 volt (-24 VDC)

(4) 0 volt (-24 VDC)

(2) Safety earth

(5) Safety earth

(3) +24 VDC

(6) +24 VDC

Figure 19: Command module power supply connections

- (1) 0 volt
- (2) Safety earth
- (3) +24 VDC

Note: The safety earth connection must be separate and not connected to the GND (ØV) connection.

Demonstration mode

In normal use, the detector remains in a reduced sensitivity mode for 24 hours while it gathers information about its environment. For purposes of demonstration, for example, to verify a new installation, this may be disabled by putting the detector into “Demonstration Mode.” This special operating mode bypasses the 24-hour learning process and allows the detector to operate at a high sensitivity after only 15 minutes learn time.

To enter demonstration mode, the detector must be in FastLearn mode. While FastLearn is running, hold down the front panel <RESET> button and while holding this, simultaneously press the <TEST> and <ISOL> buttons. The <RESET> and <ISOL> buttons do not need to be enabled for this function.

When entering demonstration mode, the detector front panel LCD display will show the legend “Demo mode” and the time and date on which this was invoked.

Note: Demonstration mode should only be used for demonstrations. It should not be used as a substitute for normal operation, as the alarm settings in this mode are based solely on the sparse data gained during the 15-minute FastLearn period. Over time, this would lead to nuisance alarms due to normal variation in the detector’s environment. To cancel demonstration mode, invoke a new FastLearn.

Interfacing with fire alarm panels

Because of the flexible nature of the detector and the many possible configurations, there are many options for interfacing the detectors to the fire panel. These include many third party interfaces available from various manufacturers. Because of this, it is not possible to give a complete list of interfacing methods but the following pages will give details of the most common methods that are likely to be used.

Setting the detector address

In order to identify itself to the command module or fire panel, each detector needs to have a unique address ranging from 1 to 127. The detector address is simply set on the red DIP switch SW1 located at the lower left of the opened detector on the bottom of the main circuit board. The switch settings are up for 1 and down for 0, and the detector address is set as a 7-bit binary code (switch 8 equates to a value of 128 and so is outside the usable address range).

Figure 20 shows an example where the address equates to “11000110” in binary, or:

$$(1 \times 1) + (1 \times 2) + (0 \times 4) + (0 \times 8) + (0 \times 16) + (1 \times 32) + (1 \times 64) + (0 \times 128) = 99$$

Figure 20: Sample DIP switch settings

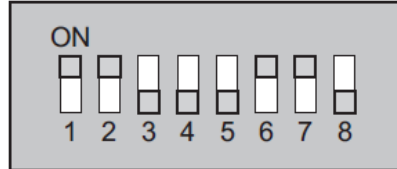

The full range of available addresses and their relevant switch settings are provided in Table 2 for reference.

Note: Addresses chosen for detectors do not have to be consecutive or in a given order as long as they are all different.

Table 2: Address table

Address	1	2	3	4	5	6	7	8
1	1	0	0	0	0	0	0	0
2	0	1	0	0	0	0	0	0
3	1	1	0	0	0	0	0	0
4	0	0	1	0	0	0	0	0
5	1	0	1	0	0	0	0	0
6	0	1	1	0	0	0	0	0
7	1	1	1	0	0	0	0	0
8	0	0	0	1	0	0	0	0
9	1	0	0	1	0	0	0	0
10	0	1	0	1	0	0	0	0
11	1	1	0	1	0	0	0	0
12	0	0	1	1	0	0	0	0
13	1	0	1	1	0	0	0	0
14	0	1	1	1	0	0	0	0
15	1	1	1	1	0	0	0	0
16	0	0	0	0	1	0	0	0
65	1	0	0	0	0	0	1	0
66	0	1	0	0	0	0	1	0
67	1	1	0	0	0	0	1	0
68	0	0	1	0	0	0	1	0
69	1	0	1	0	0	0	1	0
70	0	1	1	0	0	0	1	0
71	1	1	1	0	0	0	1	0
72	0	0	0	1	0	0	1	0
73	1	0	0	1	0	0	1	0
74	0	1	0	1	0	0	1	0
75	1	1	0	1	0	0	1	0
76	0	0	1	1	0	0	1	0
77	1	0	1	1	0	0	1	0
78	0	1	1	1	0	0	1	0
79	1	1	1	1	0	0	1	0
80	0	0	0	0	1	0	1	0
81	1	0	0	0	1	0	1	0

17	1	0	0	0	1	0	0	0
18	0	1	0	0	1	0	0	0
19	1	1	0	0	1	0	0	0
20	0	0	1	0	1	0	0	0
21	1	0	1	0	1	0	0	0
22	0	1	1	0	1	0	0	0
23	1	1	1	0	1	0	0	0
24	0	0	0	1	1	0	0	0
25	1	0	0	1	1	0	0	0
26	0	1	0	1	1	0	0	0
27	1	1	0	1	1	0	0	0
28	0	0	1	1	1	0	0	0
29	1	0	1	1	1	0	0	0
30	0	1	1	1	1	0	0	0
31	1	1	1	1	1	0	0	0
32	0	0	0	0	0	1	0	0
33	1	0	0	0	0	1	0	0
34	0	1	0	0	0	1	0	0
35	1	1	0	0	0	1	0	0
36	0	0	1	0	0	1	0	0
37	1	0	1	0	0	1	0	0
38	0	1	1	0	0	1	0	0
39	1	1	1	0	0	1	0	0
40	0	0	0	1	0	1	0	0
41	1	0	0	1	0	1	0	0
42	0	1	0	1	0	1	0	0
43	1	1	0	1	0	1	0	0
44	0	0	1	1	0	1	0	0
45	1	0	1	1	0	1	0	0
46	0	1	1	1	0	1	0	0
47	1	1	1	1	0	1	0	0
48	0	0	0	0	1	1	0	0
49	1	0	0	0	1	1	0	0
50	0	1	0	0	1	1	0	0
51	1	1	0	0	1	1	0	0
52	0	0	1	0	1	1	0	0
53	1	0	1	0	1	1	0	0
54	0	1	1	0	1	1	0	0
55	1	1	1	0	1	1	0	0
56	0	0	0	1	1	1	0	0
57	1	0	0	1	1	1	0	0
58	0	1	0	1	1	1	0	0
59	1	1	0	1	1	1	0	0
60	0	0	1	1	1	1	0	0
61	1	0	1	1	1	1	0	0
62	0	1	1	1	1	1	0	0
63	1	1	1	1	1	1	0	0
64	0	0	0	0	0	0	1	0

82	0	1	0	0	1	0	1	0
83	1	1	0	0	1	0	1	0
84	0	0	1	0	1	0	1	0
85	1	0	1	0	1	0	1	0
86	0	1	1	0	1	0	1	0
87	1	1	1	0	1	0	1	0
88	0	0	0	1	1	0	1	0
89	1	0	0	1	1	0	1	0
90	0	1	0	1	1	0	1	0
91	1	1	0	1	1	0	1	0
92	0	0	1	1	1	0	1	0
93	1	0	1	1	1	0	1	0
94	0	1	1	1	1	0	1	0
95	1	1	1	1	1	0	1	0
96	0	0	0	0	0	1	1	0
97	1	0	0	0	0	1	1	0
98	0	1	0	0	0	1	1	0
99	1	1	0	0	0	1	1	0
100	0	0	1	0	0	1	1	0
101	1	0	1	0	0	1	1	0
102	0	1	1	0	0	1	1	0
103	1	1	1	0	0	1	1	0
104	0	0	0	1	0	1	1	0
105	1	0	0	1	0	1	1	0
106	0	1	0	1	0	1	1	0
107	1	1	0	1	0	1	1	0
108	0	0	1	1	0	1	1	0
109	1	0	1	1	0	1	1	0
110	0	1	1	1	0	1	1	0
111	1	1	1	1	0	1	1	0
112	0	0	0	0	1	1	1	0
113	1	0	0	0	1	1	1	0
114	0	1	0	0	1	1	1	0
115	1	1	0	0	1	1	1	0
116	0	0	1	0	1	1	1	0
117	1	0	1	0	1	1	1	0
118	0	1	1	0	1	1	1	0
119	1	1	1	0	1	1	1	0
120	0	0	0	1	1	1	1	0
121	1	0	0	1	1	1	1	0
122	0	1	0	1	1	1	1	0
123	1	1	0	1	1	1	1	0
124	0	0	1	1	1	1	1	0
125	1	0	1	1	1	1	1	0
126	0	1	1	1	1	1	1	0
127	1	1	1	1	1	1	1	0

Connecting a detector network to a command module

The total length of interconnecting cable between adjacent detectors in the loop should not exceed 1.2 km (3/4 mile). Use a 120 ohm screened twisted pair such as Belden 9841 24 AWG for all loop connections. The RS-485 A and B wires should be taken through a ferrite (supplied) with a single loop (see Figure 16 on page 26).

The detectors are connected using the RS-485 connections on the terminal block (see Figure 14 on page 22 and Figure 15 on page 24) RS-485 1A and 1B are the signal connections for bus 1 and RS-485 2A and 2B are the signal connections for bus 2. SCREEN 1 and 2 are the screen connections for buses 1 and 2 respectively.

For the command module, the RS-485 1A and 1B connections may be thought of as the “Send” lines, and 2A and 2B the “Return” lines. For each detector on the loop, the 1A and 1B connections may be thought of as the lines from the previous detector on the loop and the 2A and 2B connections the lines to the next detector in the loop.

Fault tolerant detector loop configuration

Figure 21 shows the configuration for a fault-tolerant network.

Figure 21: Fault tolerant detector loop configuration

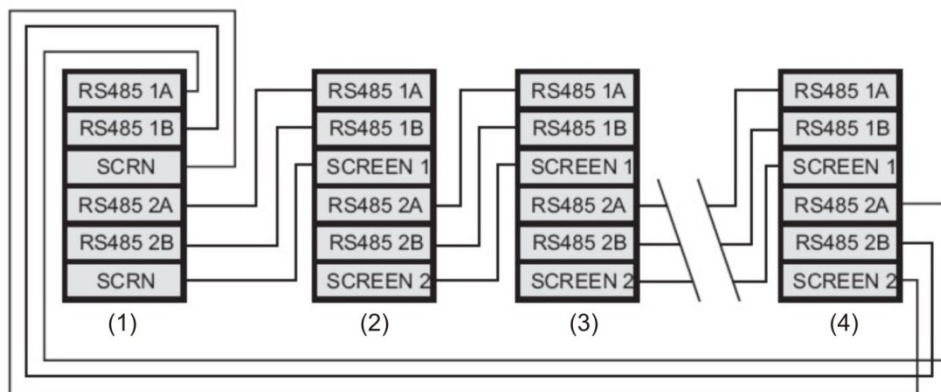

- (1) Command module
- (2) Detector 1
- (3) Detector 2
- (4) Detector 127

Non-fault tolerant serial configuration

It should be pointed out that loop connections such as in “Fault tolerant detector loop configuration” above are only needed for a fully fault-tolerant network where full isolation is required between detectors. If all detectors are operating within the same zone, a series connection can be used where the output from the

command module is taken from the Bus 2 terminals and the last detector in the loop does not require to be connected back to the command module as shown below. In this example, the command module will not be able to monitor the network for communications problems, but less wiring is required.

Figure 22: Non-fault tolerant serial configuration

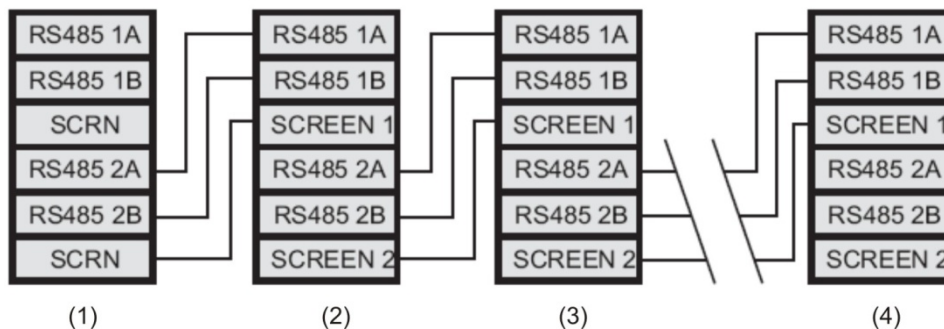

- (1) Command module
- (2) Detector 1
- (3) Detector 2
- (4) Detector 127

Connecting a command module to an addressable fire panel

When a command module is being used to manage one or more detectors (the maximum limit is 127) an Addressable Protocol Interface Card (APIC) is required to decode detector status information in the command module and convey to the fire panel via the Addressable Bus 1 and Bus 2 terminal block connections (see “Command module terminal block connections” on page 24 for details). In this configuration only one interface is required and all detector information is available through this interface, one address per device.

APICs plug into a connector on the main PCB via a ribbon cable. Once plugged in, the addressable signaling line circuit (SLC) in and out are connected to the main PCB addressable bus terminals and the address DIP switches are set to the SLC address. Refer to the APIC installation sheet for details.

Note: Some addressable protocols may limit the maximum number of device addresses to less than 127. Some protocols may not support all of the available alarm levels, and fault reporting is usually a general fault with no detailed fault information.

Figure 23: Addressable fire panel configuration

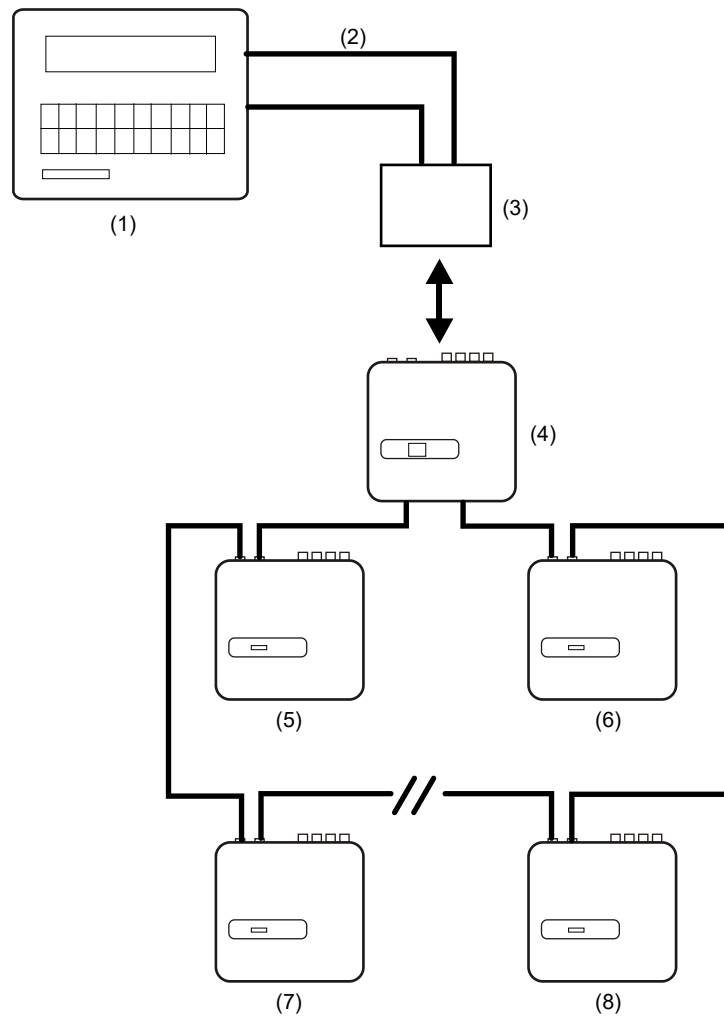

- (1) Addressable fire panel
- (2) Addressable loop
- (3) APIC mounted inside the command module detector (Start address: 1, End address: 127*)
- (4) Command module detector
- (5) Detector 1
- (6) Detector 127
- (7) Detector 2
- (8) Detector 126

*In networks of less than 127 detectors, in order to avoid unused addresses from reporting a "Detector not Present" fault, it is required that a continuous unbroken range of detector addresses is set on the APIC.

Connecting a single detector to an addressable fire panel

An APIC may be used to decode detector status information and convey this to the fire panel via the addressable Bus 1 and Bus 2 terminal block connections (see “Command module terminal block connections” on page 24 for details).

Figure 24: Connecting a single detector to an addressable fire panel

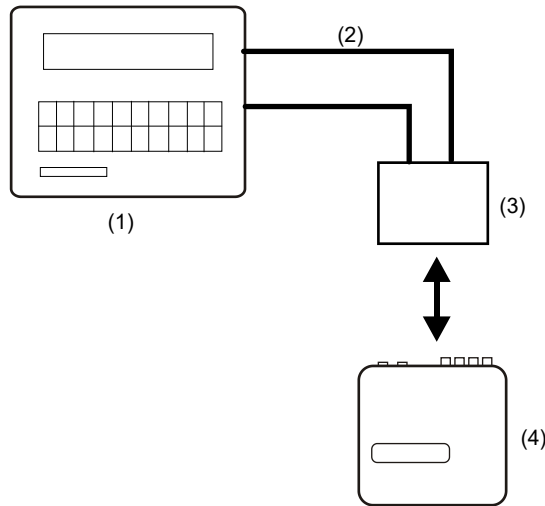

- (1) Addressable fire panel
- (2) Addressable loop
- (3) APIC mounted inside the detector (Start address: 1, End address: 1)
- (4) Detector 1

Note: The detector address on the RS-485 communications loop and the fire panel addressable protocol address are the same as no address translation is performed. Some protocols may not support all of the available alarm levels, and fault reporting is usually a general fault with no detailed fault information.

Connecting to a PC

To connect a single stand-alone detector to a PC, connect the PC's serial port directly to the detector's 9-way RS-232 port. Connections for this cable are shown in Figure 25.

Figure 25: Cable connections for connecting to a PC

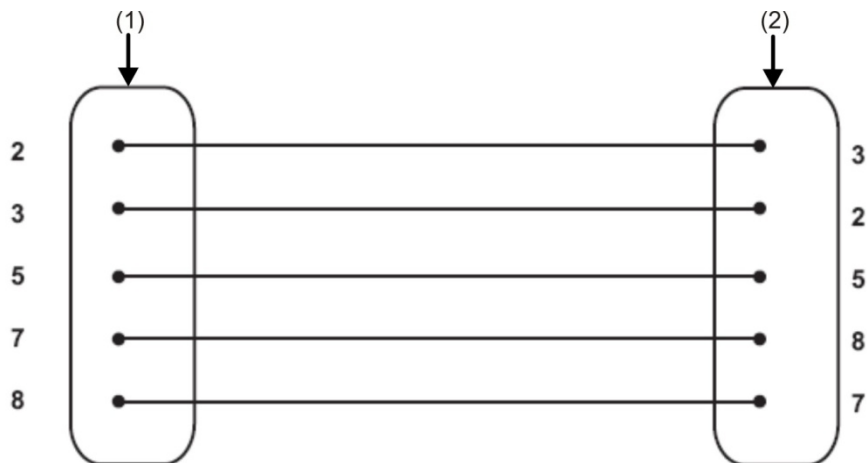

(1) 9 pin female "D" connector

(2) 9 pin female "D" connector

When multiple detectors are networked together and a command module is being used, the PC connects to the command module's 9-pin RS-232 port (see Figure 26 below). The cable connections are the same as the standard detector cable connections.

Figure 26: Connecting a PC to the command module RS-232 port



Chapter 3

Programming the unit

Summary

This chapter provides information on programming the detector.

Content

Introduction	38
Entering programming mode	38
Main menu	39
Navigating through the menus	40
Detector programmable functions	41
Time and date	44
Alarm levels	44
Alarm delays	44
ClassiFire override	44
ClassiFire alarm factor	44
Hour start of day and night operation	45
LDD enable	45
FastLearn ON	46
Auto FastLearn	46
ClassiFire 3D	46
Cascading alarms	46
Latching alarms	47
Latching faults	47
Remote day/night	47
Remote reset enable	47
Remote isolate enable	47
Programmed isolate (discontinued)	47
Detector address / number of detectors	47
Device text	48
Reference enable	48
Reference device	48
Reference level	48
Back off	48
Reset, test & isolate button enable	48
Power save	49
Battery check enable	49
Mains check enable	49
Aspirator speed	49
Flow setup	49
Airflow monitoring	50
Chart log recording rate	50
User defined access code	51
BMS protocol	51
Factory default	51
Auto-learn scan devices	52
Looped bus (class A) network wiring connection	52
Poll timeout	52
Call centre	52
Password	52
Pager	53
Page on fault	53
Page on alarm	53
View event log	53
Diagnostics	53
Detector read	53
Loop errors	53
Dust separator condition	54
Relay tests	54
Watchdog trip count	54
Event log	54

Introduction

The detector can be configured and programmed with the use of the front panel controls or interface to a PC.

Entering programming mode

The access code is required to allow the detector parameters to be programmed. The access code is only valid whilst the user is in programming mode. It will need to be entered again if programming mode is exited, if the detector is powered down, or if <RESET> is pressed.

You must re-enter the access code if you:

- Exit programming mode
- Power down the detector
- Press the <RESET> key

To enter programming mode, press one of the following program menu keys:

- <Menu>
- Right or left arrow
- <Enter>

The detector responds by prompting the user for the access code as follows:

Access code: 0000

Note: The factory default access code is 0102.

To enter the default access code, enter the following sequence:

Figure 27: Setting the access code



Note: Pressing the up or down arrow key has no effect until you press the right arrow key to place the cursor under the first digit.

All programmable functions work in a similar manner:

- Right and left arrow keys: Move the cursor position through the user-settable digits.
- Up and down arrow keys: Step through the available values for the currently-selected digit.
- <Enter> key: Enters the displayed figure.

Valid ranges for all programmable parameter values are included in Table 3 on page 42.

Note: You cannot save an illegal value. For example, the maximum valid input for the Alarm level is 10. If you enter 99, the programmer displays the Bad value error message, and prompts you to enter the value again.

After you enter the required value, press the <Enter> key to select the amended setting. Pressing the Right Arrow key when the cursor is on the right-most digit has the same effect. If no programming activity is detected for 5 minutes, the detector displays the legend Access timeout and exits programming mode.

Main menu

When the correct access code is entered, the display shows the Main menu. The current selection is always shown with an arrow after it. Press the <Enter> key or the left arrow key to activate the selection.

The choices available in the main menu are, in order:

Setup menu: Contains all the user-programmable functions.

Log menu: Displays historical information such as the event log (time and date of various events such as alarm or fault conditions).

Diagnostic menu: Contains detector self-tests.

Reset: Clears any latched fault readings or exits from a menu item to its parent menu. This has the same effect as pressing the <RESET> button.

Isolate: Isolates the detector. This has the same effect as isolating with the <ISOL> button.

Exit: Exits programming mode

Note: When you press the up arrow key in the Setup menu, the Main menu wraps around and brings up Exit, etc.

Navigating through the menus

Press the up and down arrow keys to navigate through the menu options. The currently selected item appears at the top of the screen and is identified by an arrow or a trailing dot.

Figure 28 below shows how pressing the down arrow key scrolls the screen from the Setup menu (the current selection), to the Log menu. Alternatively, pressing the up arrow retreats to the Exit command.

Figure 28: Using the arrow keys to navigate

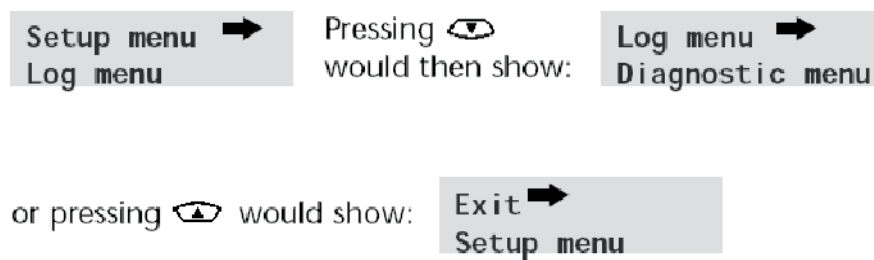

When the menu item appears with the arrow next to it, press the <Enter> key to scroll through the list of items available for that menu.

Once you reach the last entry in the sub-menu, press the <RESET> button to move back up to the Setup menu. Pressing the <RESET> button at any time exits programming mode, assuming the <RESET> button is enabled.

Table 3 shows the full menu map for the detector, showing the choices available within each menu and sub-menu.

The up and down arrow keys move the menu pointer progressively towards the left or right of the map as appropriate, and the right and left arrow keys move the pointer to the choices in the currently-selected menu or sub-menu.

Items within sub-menus are sequentially accessed with the down arrow key, followed by the right arrow key. Values are edited by pressing the right arrow key, followed by the up and down arrow keys.

Detector programmable functions

A list of all programmable functions follows with an explanation of their usage and the menu and sub-menu in which they can be found. A menu map with the location of each sub-menu and function within the main menu is shown in Table 3. The valid input range for programming parameters is also provided.

Each function listed in Table 3 gives the following information:

- Function name and description
- Type of function. There are five types of functions:
 - Yes/No
 - Numeric
 - Alpha
 - Display
 - Test
- The menu and sub-menu within which the function can be found.
- Applicability
 - The legend “CM only” means that the function applies only to the command module and is not available for the standard detector.
 - The legend “BMS CM only” means that the function only applies to the BMS variant of the command module, and is not supported by the non BMS command module.
 - The legend “Address 000-127” means that the function may apply to the command module and the standard detector (allowable addresses from 000 to 127). Time and date and Relay test are examples of these.
 - All other functions are present in both the standard detector and command module function lists and are used to program the detectors. They can either be remotely set on the command module, or set locally on the detector front panel. These are annotated “Address 001-127” since they do not apply to the command module itself.

Where a programmable function on the command module applies to a standard detector, the command module will scan the loop and, if more than one detector is present, will prompt the user for the address of the detector to be programmed.

If the function applies to the command module, the address “000” should be entered. For other detectors on the loop (including the detector element of a command module detector), the value is the same as the address set on the detector’s internal DIP switch.

If a user enters an address which does not appear on the loop, the error message, “Bad Detector” appears. This message only appears if the command module address “000” is entered into a function which only applies to detectors (that is, anything except “CM only” and “Address 000-127” functions).

Table 3 shows a map of the programmable functions by menu and sub-menu with references by chapter section.

Table 3: Menu reference table

Menu	Submenu	Programmable function	Page
Setup Menu	Time and Date	Time HH:MM	44
		Date DD:MM:YYYY	
	Alarm Levels	Alarm 2 level (1-25)	44
		Alarm level (8-10)	
		Pre-Alarm level (3-8)	
		Aux. Alarm level (2-10)	
		Alarm 2 delay (0-90)	44
		Alarm delay (0-90)	
		Pre-Alarm delay (0-90)	
		Aux. Alarm delay (0-90)	
		Class. override (0-99)	44
		Alarm factor (0-8)	44
		Day start (0-23)	45
		Night start (0-23)	
		LDD enable (Yes/No)	45
		FastLearn On (Yes/No)	46
		Auto FastLearn (Yes/No)	46
		Alarm Actions	Delay override (Yes/No)
	Cascading alarms (Yes/No)		46
	Latching alarms (Yes/No)		47
	Latching faults (Yes/No)		47
	Remote day/night (Yes/No)		47
	Remote reset (Yes/No)		47
	Remote isolate (Yes/No)		47
	Prog. Isolate On (Discontinued)		47
	Detector	Detector address	47
		Device text	48
	Reference	Reference enable (Yes/No)	48
		Reference device (1-127)	48
		Level (0-99)	48
		Back off (0-99)	48
	Front Panel	ISOLATE enable (Yes/No)	48
		TEST enable (Yes/No)	48
RESET enable (Yes/No)		48	

Menu	Submenu	Programmable function	Page
Setup Menu	Power Checks	Power save (Yes/No)	49
		Battery check enable (Yes/No)	49
		Mains check enable (Yes/No)	49
	Air Flow	Aspirator speed (1-16)	49
		Flow setup (Yes/No)	49
		Sensor 1-4 enable (Yes/No)	50
		Flow pipe 1-4	50
		Flow low 1-4 (0-99)	50
		Flow high 1-4 (0-99)	50
	Miscellaneous	Chart rate (0-19)	50
		Access code (0-9999)	51
		BMS protocol (0-3) (BMS CM only)	51
		Factory default (Yes/No)	51
	Bus Setup (BMS CM only)	Scan for devices (Yes/No)	52
		Numbers and addresses of detectors	52
		Looped bus (Yes/No)	52
		Poll timeout (48-992)	52
	Pager (BMS CM only)	Call center	52
		Password	52
		Pager	53
Page on fault (Yes/No)		53	
Page on alarm (Yes/No)		53	
Log Menu	View event log	200 Events (000-127)	53
Diagnostic Menu	Diagnostics	Self-Test Mode (1-127)	53
	Detector read	Detector Read (1-127)	53
	Loop errors	Loop Errors (Port 1 and Port 2)	53
	Dust separators	0-100% (1-127)	54
	Relay test	Aux. Alarm	54
		Pre-Alarm + Fault	54
		Alarm + Fault	54
		Alarm 2 + Fault	54
Fault		54	
Watchdog count	Number of interruptions	54	
Reset			39
Exit			39

Time and date

Numeric – Address 000-127: It is important that the time and date be set up correctly on the controller's internal calendar/clock because it uses this information to store events in the event log. Refer to "Event log" on page 54 for more details. Units are supplied with the correct setting for UK time. This is backed up with a rechargeable battery.

Alarm levels

Numeric – Address 001-127: The value set in the Pre-Alarm level, Alarm level and Aux. Alarm level functions in the Alarm levels sub-menu is the relatively-scaled bar graph level at which the appropriate alarm is initiated on the detector. The Alarm 2 level function assigns an absolutely-scaled alarm level in % obs/ft. or % obs/m (as selected in configuration) to the Alarm 2 alarm. The Aux. Alarm level is set by factory default at level 10, which means that this alarm will occur after the Alarm level.

Alarm delays

Numeric – Address 001-127: The alarm delay is the number of seconds that an alarm level has to be continuously sensed before the alarm is initiated. Each alarm level has a programmable delay of between 0 and 90 seconds.

ClassiFire override

Numeric – Address 001-127: When this function is set to a value other than zero, the shorting together of one of the "Input 3" contacts on the detector main circuit board by means of potential-free dry contacts will desensitise the detector by moving the alarm levels out by the specified percentage.

ClassiFire alarm factor

0-8 – Address 001-127: The detector sensitivity is set with this entry, which will also affect the probability of nuisance alarms. 0 = high sensitivity, higher probability; 8 = low sensitivity, lower probability.

Note: The highest sensitivity setting is suitable for clean, environmentally controlled environments, e.g., semiconductor manufacturing clean rooms where airborne pollutants are kept to an absolute minimum and the least contamination is cause for alarm. Use of this setting in a busy machine shop would lead to relatively frequent nuisance alarms due to the normal variation of atmospheric contamination, and a lower sensitivity setting is recommended. It is therefore important that the alarm factor chosen is suitable for the area to be protected. When the appropriate alarm factor for the protected area has been set, nuisance alarms will be reduced to an absolute minimum.

Table 4: Suggested Settings for ClassiFire Alarms

Alarm factor	Sensitivity	Probability of nuisance alarm	Suggested protected area
0	Extremely high	Once per year	Semiconductor manufacturing clean room
1	High	Once per 5 years	Computer room
2	High	Once per 10 years	Non-smoking office
3	High	Once per 50 years	Clean factory
4	Medium	Once per 1,000 years	Warehouse
5	Medium	Once per 5,000 years	Warehouse with diesel trucks operating
6	Medium	Once per 10,000 years	Warehouse with diesel trucks operating
7	Low	Once per 20,000 years	Warehouse with diesel trucks operating
8	Low	Once per 100,000 years	Warehouse with diesel trucks operating

Hour start of day and night operation

Note: This information is provided as general guidance only. The installer is responsible for assessing the environment and determining the appropriate sensitivity of the ClassiFire alarm.

0-23 – Address 001-127: These values are the times to the nearest hour at which the day/night switching is desired to take place on the detector. Entries are made in 24-hour format, e.g., 19:00 for 7pm. If no day/night switching is required, then both entries should be set to 00:00. Day and night switching is intended so that the detector may automatically select a different sensitivity when the protected area is unoccupied and fewer contaminants are being produced. ClassiFire automatically detects the change in smoke level after the protected area is left, and if the time at which this happens is within +/- 70 minutes of the programmed switchover time, it selects the nighttime histogram.

Note: If the environment actually becomes more contaminated during the night period, then ClassiFire will adapt to that too, reducing the nighttime sensitivity. The system will automatically compensate for 1 hour seasonal time changes.

LDD enable

Yes/No – Address 001-127: When this function is set to Yes, Laser Dust Discrimination (LDD) increases the response time of the detector slightly, while greatly reducing the likelihood of nuisance alarms due to dust ingress. LDD may be disabled in very clean rooms for a slightly faster response to smoke by setting this function to No. Disabling LDD is not recommended for areas other than manufacturing clean rooms, due to the increased probability of nuisance alarms in most other operating environments.

FastLearn ON

Yes/No – Address 001-127: Setting this function to Yes will start a FastLearn at any time. The bar graph display on the front of the detector will show a rolling segment display on the front panel for the 15 minutes that it takes to complete.

Note: If the detector is in FastLearn Mode, do not set this function to “No.” If you set this function to “No”, the FastLearn process will stop. Carrier Fire & Security does not recommend or support the deactivation of the FastLearn function.

The text display will initially display the legend FastLearn 15 and will then count down each minute until the FastLearn is complete.

Note: It will take a further 24 hours after the FastLearn for full sensitivity to be reached, unless Demonstration Mode has been initiated. It is essential for proper functioning that the detector not be left in Demonstration Mode, and that it be allowed to complete the 24-hour learning period. To cancel Demonstration Mode, set this function to Yes or power down and restart the detector to initiate FastLearn Mode.

Auto FastLearn

Yes/No – Address 001-127: As default, this function is set to Yes. This ensures that if the detector is powered down for any reason (e.g., for maintenance or to be moved to a new area), FastLearn begins automatically on power-up. There may be occasions when it is desirable to power down the detector for short periods of time, and it is highly likely that ambient contaminant levels will be the same on power-up. Under these circumstances, it may not be necessary to perform a FastLearn process again. In this case, this function can be set to No before power-down, allowing the detector to return to its original settings on power-up.

ClassiFire 3D

Yes/No – Address 001-127: If this function is set to Yes , then the detector will ignore any pre-set time delays in the event of an unacceptably rapid increase in smoke density, thereby minimising response time to “rapid growth” fires. This function would normally only be used where there were long time delays programmed on the alarm levels.

Cascading alarms

Yes/No – Address 001-127: Setting this function to Yes means that the controller starts counting down the main Alarm delay only when the detector’s controller is in Pre-Alarm state (which means that time delays on Pre-Alarm and Alarm are cumulative). The Aux. Alarm is not included in the cumulative delay since it may be set to a higher level than either the Pre-Alarm or Alarm levels.

Latching alarms

Yes/No – Address 000-127: When this function is set to Yes it requires a reset on the front panel or a remote reset to clear an alarm condition. It may be applied to the command module or a Standard detector.

Latching faults

Yes/No – Address 000-127: When this function is set to Yes it requires a reset from the front panel or a remote reset to clear fault indications. This is the factory default setting. It may be applied to the command module or a standard detector.

Remote day/night

Yes/No – Address 001-127: Setting this function to Yes allows the detector to be manually switched between day and night mode using a remote input.

Remote reset enable

Yes/No – Address 000-127: If remote resetting of the detector or command module is required from the host fire alarm controller or other external source, this option must be set to Yes.

Remote isolate enable

Yes/No – Address 000-127: When this function is set to Yes, a remote switch may be used to isolate the detector or command module.

Programmed isolate (discontinued)

This function is no longer supported. To isolate the detector, use the Isolate function.

WARNING:

To avoid potential safety risks, do not use the Programmed Isolate function.

If a detector is isolated (disabled) using Programmed Isolate, there is no visual indication on the detector, command module, or control panel that the device is not operational, and the function is not disabled automatically after 7 days.

The use of the Programmed Isolate function is entirely at the operator's own risk.

Detector address / number of detectors

Display – Address 000-127: In the case of the standard detector, this function displays the current address of the detector as set by the internal DIP switch. On the command module, it shows the number of detectors found on the

communications loop. This function appears immediately on entering the Detector sub-menu. The command module is always at address '000'. When the command module unit is fitted in a detector, the detector must have a separate address.

Device text

Alpha – Address 000-127: This is the default text string displayed on the standard detector or command module LCD display. If desired, this can be altered to any 16-character alphanumeric identification. For example, the name of the area being protected, or the name of the person responsible for fire safety could be entered. The default device text is the detector model and the firmware revision level for the standard detector, and “command module” and the firmware revision level for the command module.

Reference enable

Yes/No – Address 001-127: Setting this function to Yes enables the reference for the detector, if one has previously been allocated in Reference device (1-127).

Reference device

Numeric – Address 001-127: Any detector on the loop may use another detector as a fresh air reference. When entering the Reference sub-menu, the user is prompted to first select the address of the detector which will be using the reference, and is then forwarded to this option. To set a detector as a reference detector, enter its address as set by its internal DIP switch into this function.

Reference level

0-99 – Address 001-127: The value set with this function is the percentage reference signal subtracted from the detector's signal, if a reference device has been allocated.

Back off

0-99 – Address 001-127: This value is the delay time (in seconds) between a buildup of pollution being seen by the reference (if used) and the pollution being seen by the detector.

Reset, test & isolate button enable

Yes/No – Detectors 000-127: The front panel buttons may be enabled or disabled individually for the command module or standard detectors by setting these functions to Yes or No.

Power save

Yes/No – Address 001-127: This function allows the detector to minimise electrical power consumption when operating from stand-by batteries. If enabled, upon main supply failure the aspirator (fan) will reduce speed to minimum, regardless of the user-defined value. (See “Aspirator speed” below for details.)

This function has no effect on the command module.

Note: When in this condition, any smoke reading above 3 bar graph segments on the detector will automatically remove this condition.

Battery check enable

Yes/No – Address 000-127: If no battery back-up is required, this function should be set to No to avoid Battery fault being displayed on the front panel. If a back-up battery is used, it is recommended that the battery check be enabled. When this is done the user will be prompted for an input terminal to use. The battery fault will be displayed when this contact is open. The default setting is battery fault enabled on “I/P 1”. “Detector terminal block connections” on page 22 and Command module terminal block connections” on page 24 of this manual show the input terminal connections for the standard detector and command module, respectively.

Mains check enable

Yes/No – Address 000-127: The detector and command module are capable of signaling power supply faults from the power supply equipped with a fault relay. The mains check is disabled by default. If the feature is set to “Yes”, the user will be prompted with an unassigned input terminal to use (this will normally be “I/P 2” if battery check is already enabled on “I/P 1”. The mains fault will be displayed when this contact is open.

Aspirator speed

1-16 – Address 001-127: The value entered here sets the detector aspirator speed to a range of 1 through 16 predetermined speeds. The lower the value of the number entered, the lower the airflow rate and, therefore, the less the power consumption will be.

Flow setup

Yes/No – Address 001-127: Setting this function to Yes puts the detector into automatic flow limit setup mode. This takes a few minutes to set the flow fault thresholds based on the current flow rates.

Airflow monitoring

Display / Numeric – Address 001-127: There are separate Sensor pipe, Flow low, Flow high and Flow pipe parameters for each pipe (1 to 4) on the detector.

For example, Flow pipe 1 indicates the current airflow rate for pipe 1.

Sensor pipe 1 to Sensor pipe 4 are used to enable or disable flow sensing on the specified pipe inlet of the detector. If any pipe inlets are unused, set the relevant flow sensor function for the pipe inlet to No to avoid unwanted flow faults.

Flow low is the level below which airflow needs to be reduced to trigger a fault reading (which may indicate a blocked pipe).

Flow high is the level above which airflow needs to increase to trigger a fault indication (which may indicate a loose or damaged pipe).

Flow low and Flow high parameters are automatically set up on initial power-up or when Flow setup is selected (See “Flow setup” on page 49 for details.)

The airflow rates Flow pipe 1 to Flow pipe 4 are for display purposes only and cannot be changed.

Chart log recording rate

0-19 – Address 000-127: This function controls how frequently the detector and alarm level or flow rates are stored in the standard detector or command module internal chart recorder log.

Table 5 shows the chart log recording rates.

Table 5: Chart log recording rates

Setting	Type	Storage interval	Time per division on chart log
0	Detector level and alarm level	1 second	10 seconds
1	Detector level and alarm level	5 seconds	50 seconds
2	Detector level and alarm level	12 seconds	2 minutes
3	Detector level and alarm level	30 seconds	5 minutes
4	Detector level and alarm level	1 minute	10 minutes
5	Detector level and alarm level	2 minutes	20 minutes
6	Detector level and alarm level	5 minutes	50 minutes
7	Detector level and alarm level	10 minutes	100 minutes
8	Detector level and alarm level	20 minutes	200 minutes
9	Detector level and alarm level	50 minutes	500 minutes
10	Detector level and airflow	1 second	10 seconds
11	Detector level and airflow	5 seconds	50 seconds
12	Detector level and airflow	12 seconds	2 minutes
13	Detector level and airflow	30 seconds	5 minutes

Setting	Type	Storage interval	Time per division on chart log
14	Detector level and airflow	1 minute	10 minutes
15	Detector level and airflow	2 minutes	20 minutes
16	Detector level and airflow	5 minutes	50 minutes
17	Detector level and airflow	10 minutes	100 minutes
18	Detector level and airflow	20 minutes	200 minutes
19	Detector level and airflow	50 minutes	500 minutes

In Table 5, the greyed section indicates flow rate recording while the white section indicates detector and alarm level recording.

The factory default setting is 8. At the slowest recording rate, one month of data can be recorded. A PC must be connected via the RS-232 port with appropriate software to view the chart event log. (See “Connecting to a PC” on page 35 for details on how to connect to a PC.)

User defined access code

0-9999 – Address 000-127: This function sets the access code that the user has to input in order to modify any of the function values. The default setting is “0102” but for added security it can be changed to any four-digit number desired by the user.

BMS protocol

0-3 – BMS CM only: This function sets the communications protocol for connection to a Building Management System (BMS). (See Appendix A “External communications” on page 71 for details on how to set up external communications).

Factory default

Yes/No – Address 000-127: On the standard detector, this function has two purposes. If the user has changed any of the detector’s functions, this function will display No, indicating that the detector is not at factory default. Setting the function to Yes will restore the detector to the factory default settings. On the command module, this setting returns all detectors on the communications loop to their default settings. To default an individual detector in the loop, it is necessary to use the detector’s own front panel.

Auto-learn scan devices

Yes/No – CM only: Setting this function to Yes causes the command module to scan the RS-485 data bus for connected detectors. While scanning, the display will show Scanning loop and display a progress bar. When finished, the display will show the number of devices found and the detector addresses in the form. The list “wraps around,” so that pressing up arrow when viewing Address 001 brings up detector number 127. Pressing right arrow allows the user to remove a detector address from the loop (by changing “Y” to “N”), or to re-instate a previously removed detector (by changing “N” to “Y”). This is different from the Isolate function in that a fault is still generated on the command module. However, this may need to be done if replacing a detector on the loop so that the detector’s address becomes available to the replacement. After replacing the detector, the address may be re-enabled.

Looped bus (class A) network wiring connection

Yes/No – CM only: This function is set to Yes to signify that the detectors are connected to the command module in a fault tolerant loop configuration (See “Fault tolerant detector loop configuration” on page 31 for further setup information.) Failing to set this value to Yes for a loop configuration will mean that the fault monitoring advantages of the detector loop are lost. Setting the value to Yes for a non-fault tolerant configuration will generate detector loop errors, so it is important that the appropriate configuration is identified.

Poll timeout

48-992 – BMS CM only: This is the time, specified in milliseconds, which a device has to respond to a poll from the command module. If no response is received for this time then, a Comms fault message is shown for this device on the command module display. This may be caused by communications delays, e.g., when units are communicating across a Wide Area Network. This function may then be set to a more suitable value.

Note: If in doubt about the setting of this function, please contact Technical Support.

Call centre

Numeric – CM only: This is the phone number the modem dials up to send a message. For more detail on this and the other functions in the “Pager” sub-menu, refer to Appendix A “External communications” on page 71.

Password

Alpha – CM only: This is an optional password used to access the system.

Pager

Numeric – CM only: Note: This is the number of the actual pager.

Page on fault

Yes/No – CM only: Where a pager has been allocated as above, this function determines whether the pager holder is to be paged when a fault condition is generated by the command module.

Page on alarm

Yes/No – CM only: Where a pager has been allocated as above, this function determines whether the pager holder is to be paged when a fire alarm condition is generated by the command module.

View event log

Display – Address 000-127: This function shows the start and stop time and date of events such as FastLearn, alarm condition and error messages. (See “Event log” on page 54 for more information on logging events.) The event log can also be downloaded to a PC via the RS-232 serial port. (See “Connecting to a PC” on page 35 for details on how to connect to a PC.)

Diagnostics

Test – Address 001-127: This function puts the detector into self-test mode. On a command module, it tests all detectors on the loop.

Detector read

Display – Address 001-127: This function displays five values as shown:

010.5%

064 067 066 067

The top value is the detector’s current smoke level reading as a percentage of the full-scale value, and the bottom four readings are the current flow rates on each pipe. The flow rates are scaled based on the application. The absolute flow reading is less important than a change in the reading.

Loop errors

Display: This displays the percentage of loop errors in messages addressed to the detector or command module from the detector loop, along with a count of the number of received messages since the last message was received on port 1 and port 2 of the RS-485 bus.

Dust separator condition

Display – Address 001-127: The value given at this function is the efficiency rating of the dust separator (filter) in the detector. A new cartridge will give the reading Separator 100.0% in this function. When the efficiency has decreased to 80%, the Fault indicator LED will illuminate and the text display will show Separator renew.

If the separator (filter) cartridge is missing or improperly fitted, the display will read Separator change. Installing a new cartridge will automatically reset this figure to 100%.

Relay tests

Test – Address 000-127: This tests the connection of the command module or detector to an alarm panel by operating the alarm or fault relay currently selected. Assuming proper connection, this should give appropriate indications on the fire panel. The test runs through the sequence:

Aux. Alarm > Pre-Alarm + Fault > Alarm + Fault > Alarm 2 + Fault > Fault

The test steps to the next test on the list when you press the ENTER key. Although the relevant relays are activated at each stage, the associated lights on the front panel are not illuminated or recorded in the event log.

Caution: Operating the alarm or fault relays will physically activate and switch the contacts. Ensure that the receiving fire panel is in test/maintenance mode before initiating this test.

Watchdog trip count

Display: The watchdog is a circuit built into the controller that restarts the controller in the event of a failure to function properly. This could be as a result of electrical spikes. This count shows the number of interruptions found. The details of each problem can be found in the event log.

Event log

An event is defined as operation of any of the front panel controls (when enabled), a signal received from a remote source (e.g., the command module or PC), a detector level exceeding the Aux. Alarm, Pre-Alarm, Alarm or Alarm 2 thresholds or certain commands sent from the Remote software or SenseNET. The event log will also store items such as day and night start times, demonstration mode, power fault, detector fault, etc. The detector keeps a log of the last 200 events for reference purposes.

The event log can be downloaded using a PC that has the remote software installed and is connected to the detector's RS-232 port using a serial cable. (See "Connecting to a PC" on page 35 for details on how to connect to a PC.)

The event log can also be viewed in the Log menu , which prints out the event log in reverse order, i.e., the last recorded event is printed out first.

When the buffer that stores events is full (200 events are stored) and a new event occurs, the oldest event in the buffer is discarded.

Chapter 4

Commissioning

Summary

This chapter provides information to commission the detection system.

Content

Introduction	58
Commissioning	58
Precommissioning preparation	59
Acclimation period	59
Transport time verification	60
Gross smoke testing	60

Introduction

This chapter covers the commissioning procedures for the detector. Before commissioning the detector the local standards of aspirating detection systems must be consulted. These standards differ widely throughout the world and specific advice for the market in one country may not be applicable to another.

Commissioning strategy will initially depend upon the environment in which the detector is installed. For instance, the test for a computer room (which should be a relatively clean environment) would be very different from, say, a flour mill, which would probably have a high level of airborne particulate content.

A widely accepted standard for computer rooms/EDP areas is British Standard BS 6266, equipment overheating at a stage well before combustion. To perform the test electrically overload a 1 m (3.3 ft.) length of PVC insulated wire of 10/0.1mm gauge for one minute using an appropriate power supply. The detector has two minutes from the end of the wire burn to give an alarm indication.

For areas with higher levels of background particulate matter testing methodology would be similar to that of standard point detectors.

Commissioning

The following brief checklist allows quick setup of the detector. This procedure will be adequate for most standard installations.

To commission the detector:

1. Before powering up the detector, visually check all cabling to ensure correct connection. If wire identification is not immediately clear (e.g. by use of different colored wires or wire identification sleeves), an electrical check should be made. Any damage caused by misconnection of the detector is not covered by warranty.
2. Caution: Ensure all wiring connections are checked prior to powering up the detector. Incorrect wiring of the detector will cause permanent damage to the detector.
3. Power up the unit and enter the access code. The factory default setting for this is 0102. (See “Entering programming mode” on page 38 for details).
4. Ensure all detectors in the network are clear of troubles and alarms, if applicable.
5. Enter the Setup menu and verify that the time and date are correct. (See “Time and date” on page 44 for details.)
6. Set an appropriate alarm factor for the protected environment. The detector will perform a FastLearn for the new alarm factor. (See “ClassiFire alarm factor” on page 44 for details.)

7. When the detector is still in FastLearn mode, exit the programming mode on the display by pressing <RESET> and set the detector into Demonstration Mode (see “Detector programmable functions” on page 41 for details). To do this, press and hold down the <RESET> button and simultaneously depress the <TEST> and <ISOL> buttons. The text display will then display “Demo mode” and the time and date.
8. Wait for the FastLearn to finish (when the legend FastLearn is no longer displayed and the “rolling” LED indications stop sequencing) and perform any necessary smoke tests, ensuring that the detector reacts appropriately, and let the smoke fully dissipate.
9. Perform another FastLearn, this time not putting the detector into Demonstration Mode. The detector will generate no alarms during the 15-minute FastLearn period, and after this, the detector will operate at a reduced sensitivity for 24 hours while ClassiFire acclimates to the protected environment and sets up appropriate day and night sensitivity settings.

Precommissioning preparation

Commissioning is recommended after all construction has been completed and cleaned of any lingering post-construction dirt. If ambient monitoring conditions are recorded before the installation is cleaned up, they may not accurately reflect actual normal operating conditions that need to be used as reference data for follow-up maintenance procedures and tests.

Acclimation period

The detector will operate at a reduced sensitivity for 24 hours. ClassiFire will set up the appropriate day and night sensitivity settings. All air handling units, thermostats and other systems that can have an effect on the operating environment should be turned on to simulate normal operating conditions as closely as possible. After approximately one week of monitoring time (depending on chart log recording rate), download the detector event log to a PC from the RS-232 port using a serial cable.

Transport time verification

The maximum transport time verification test is the measure of the amount of time it takes for the detector to respond to smoke that enters the pipe at the sampling point furthest from the detector. The results of this test and the calculated maximum transport time from PipeCAD must be recorded on the checksheet. Measured transport time less than the calculated time is acceptable.

To measure the maximum transport time of the system:

1. Determine the furthest sampling point from the detector.
2. Allow test smoke to enter the pipe at the furthest sampling point.
3. Record the amount of time for the detector to respond. This is the actual maximum transport time.

Gross smoke testing

The gross smoke test is a measurement of the amount of time elapsing from the activation of the smoke generating medium, until Pre-Alarm and Alarm is reached. This test should be repeated at least three times with consistent results. Recommended smoke generating medium is simulated smoke or wire burner.

Chapter 5

Troubleshooting

Summary

This chapter provides information to troubleshoot the detection system.

Content

Troubleshooting the detector 62

Error messages 64

Troubleshooting the detector

This chapter provides some possible solutions if a problem should occur with your detector. If the problem is not addressed in this chapter or, if after performing the suggested actions, the problem persists, contact Technical Support.

Table 6: Troubleshooting guide

Problem	Solution or corrective action
Pressing <Reset> or <Isol> button has no effect	Check that the controls have been enabled. These functions are disabled by default. (See “Reset, test & isolate button enable” on page 48 for details.)
Nuisance alarms occur too often	<p>Check that the ClassiFire alarm factor setting is appropriate for the normal working environment of the protected area. (See “ClassiFire alarm factor” on page 44 for details.)</p> <p>Check that the detector is not in demonstration mode. This can be ascertained by viewing the event log and checking that the entry Demo Mode has a higher log entry number than the most recent FastLearn start and FastLearn end entries. (See “View event log” on page 53 and “Event log” on page 54 for details.) Remember that the log entries are in reverse order, with the most recent entries appearing first. If the log shows that demonstration mode was invoked during the last FastLearn period, start a new FastLearn and allow it to complete its 24-hour cycle. (Refer to “FastLearn ON” on page 46 for details.)</p> <p>From the event log, check that at least 24 hours have elapsed since the last FastLearn end entry. (See “View event log” on page 53 and “Event log” on page 54 for details.)</p> <p>Check that day-night switchover times are appropriately set to reflect active and non-active periods. (Refer to “Hour start of day and night operation” on page 45 for details.)</p>
Elevated smoke levels do not generate alarms	<p>Check that detector is not Isolated or in FastLearn (if Isolated, the Fault light will be lit).</p> <p>Check that the detector sampling points are in the smoke stream.</p> <p>Check that unused sampling pipe ports are closed and that sampling pipes are firmly and cleanly seated in their ports and undamaged.</p> <p>Check that the correct ClassiFire alarm setting has been set. (Refer to “ClassiFire alarm factor” on page 44 for details.)</p> <p>Check that the detector has either had a 24 hour learning period or that it has been placed in demonstration mode.</p>
Low mean output	Check that the dust separator (filter) does not require changing (refer to “Dust separator condition” on page 54 for details) and that the air plenum chamber is clean. The chamber may become clogged when, for example, heavy building activity has occurred near the sampling pipes. If so, the chamber may require factory service. The detector is not designed to handle large quantities of coarse debris and dust.
Detector sensitivity varies over time	There are many reasons why particle densities may vary, and the ClassiFire system automatically compensates for this in order to replace the likelihood of nuisance alarms due to normal variations in background smoke density. Within limits set by the ClassiFire alarm factor, this is a normal part of the detector’s operation.

Problem	Solution or corrective action
Flow fault errors	<p>These occur when the airflow rate into the detector exceeds the preprogrammed parameters. As the detector “learns” the flow setup from the initial installation, this usually means that there has been some change in conditions.</p> <p>If the detector input is sampled from one area and the exhaust is in another area with different pressure (e.g., the detector is in a roof space and sampling from an enclosed room), this may lead to flow faults. In this case, it would be necessary to lead a pipe from the exhaust to the protected area to ensure nominal flow.</p>
“Low Flow” error message	<p>Check that the pipe giving the error is not blocked.</p> <p>If the pipe is unused, check that the flow sensor for this pipe has been disabled. (Refer to “Airflow monitoring” on page 50 for details.)</p> <p>Check that the low flow fault threshold is not set too high. (Refer to “Airflow monitoring” on page 50 for details.)</p> <p>Consider increasing the aspirator (fan) speed. (Refer to “Aspirator speed” on page 49 for details.)</p>
“High Flow” error message	<p>Check that the pipe is pushed home into the inlet and is not broken or cracked.</p> <p>Check that installed pipework is fitted with endcaps. PipeCAD pipe modeling software prompts for the use of appropriate endcaps. Open bore pipes are not recommended.</p> <p>Check that the high flow fault threshold is not set too low. (Refer to “Airflow monitoring” on page 50 for details.)</p> <p>Consider reducing the aspirator (fan) speed. (Refer to “Aspirator speed” on page 49 for details.)</p>
Cannot refit the front cover	<p>Check that the recessed top edge of the cover is securely located behind the locating guard rails on the chassis.</p> <p>Check that the key is turned to the unlocked position (counter-clockwise).</p>
No display	<p>Check that the display ribbon cable is securely connected to the detector/command module main board and to the display board as appropriate.</p> <p>Check that the display ribbon cable has not been damaged.</p>

Error messages

The detector front panel display can provide a wide range of information about the detector. Table 7 lists error messages and their meanings.

Table 7: Error messages

Error message	Meaning and suggested action
Separator renew	The dust separator (filter) requires replacement.
Separator change	The dust separator (filter) is missing or improperly fitted.
Bad value, Bad time, Bad date	A value has been input into a function, which is outside the parameter range for that value. Take note of the range of values allowed (in brackets) and try again.
Bad detector	A detector address has been entered which is either outside the allowed range or which is not present on the loop. This may also happen if the user has entered address 000 (command module) for a function which it does not support (e.g., alarm factors).
No response	The command module has unsuccessfully attempted to read a function value from a connected unit. Check that the unit connected supports this function.
001 X 002 Loop break	There is a break in the communications loop between the detector addresses specified. Check the wiring.
Comms fault	The command module has polled a detector and no response has been received after the specified poll timeout value. (See "Poll timeout" on page 52 for details.)
Bad access code	An incorrect access code has been entered. Enter the correct code.
Battery fault	This indicates either that the standby battery has discharged to a predetermined level or that no standby battery is fitted. In the former case, the battery should be replaced and recharged. In the latter case, the battery check should be disabled. (See "Battery check enable" on page 49 for details). It is important that the battery fault be acted upon as soon as noticed, as excessive discharge may cause damage to the battery. The battery fault condition occurs before the battery reaches this portion of the discharge curve.
Watchdog reset	This indicates that there has been a power supply fault. If there are frequent power outages, it may be advisable to power the unit from a UPS.
Detector fault	This indicates that there is a problem with the detector head. This may be due to a number of causes. Refer to the chart readout if this can be downloaded to a PC and note the detector signal level at the time of the fault. When as much information as possible has been determined about the conditions at the time of the error, please contact Technical Support.

Chapter 6

Maintenance

Summary

This chapter provides scheduled and unscheduled maintenance procedures.

Content

Introduction	66
Scheduled maintenance	66
Maintenance procedures	67
Visual check	67
Gross smoke test	67
Transport time verification test	67
Detector sensitivity test	68
Cleaning the detector	68
Replacing the dust separator (filter) cartridge	69

Introduction

This chapter contains maintenance instructions for the detection system. These procedures should be performed on a scheduled basis. In the event that system problems are found during routine maintenance, refer to Chapter 5 “Troubleshooting” on page 61.

Scheduled maintenance

The scheduled maintenance of the system should be performed at an established interval. The interval between performance of maintenance procedures should not exceed any imposed regulations. (See NFPA-72 or other local requirements.)

Local standards and specification requirements must be adhered to. A typical maintenance plan is listed in Table 8 below.

Notes

It is prudent to disconnect or isolate the detector from the fire panel during maintenance to prevent unintentional alarm activations.

The detector should be powered down during internal cleaning (use an air duster can or dry air gun).

Table 8: Maintenance plan

Step	Procedure
1	Check detector, wiring, and pipework for damage
2	Check original design is still valid, e.g. changes due to building upgrades
3	Check detector for contamination and clean if necessary
4	Check maintenance logs for issues and rectify as appropriate
5	Check transport times against original records: significant increases or decreases in transport times may imply damaged pipes or sampling holes that need clearing
6	Isolate detector from fire panel if required
7	Smoke test to check detector operation and Alarm relay connection
8	Simulate a fault to check the fault relay and connection
9	Complete and file maintenance records
10	Reconnect detector to fire panel if required

Maintenance procedures

The following paragraphs outline general scheduled maintenance procedures to be performed on an “as necessary” basis.

Caution: Risk of equipment damage. Always turn the power off before servicing the detector.

Visual check

The visual check must be performed every six months. This check is to ensure pipe network integrity.

To perform the visual check, observe the entire piping network and check for abnormalities in the pipes, including any breaks, blockages, crimps, etc.

Gross smoke test

The gross smoke test is a Go/No-Go test which ensures that the detector responds to smoke. This test must be performed at system commissioning and every year thereafter. To perform this test, smoke must be introduced into the last sampling hole in each branch of the pipe network and the proper response must be verified by the detector. Smoke from a punk or cotton wick may be used.

Note: For cleanroom applications, consult with supplier for gross smoke test methods.

Transport time verification test

The maximum transport time of the pipe network must be measured and compared to the recorded transport time at commissioning. (Refer to “Transport time verification” on page 60 for test details.) The transport time verification test must be done at commissioning and every year thereafter.

Detector sensitivity test

The detector sensitivity test must be performed within one year of installation and every alternate year thereafter.

Example:

- Year-one check
- Year-three check
- If years one and three are OK, go to five-year interval.

The detector employs a self-monitoring, automatically-adjusting calibration for the system. The inspection only requires a periodic visual inspection for a detector fault indication and performing the detector sensitivity test function.

If the self-monitoring feature of the system senses that the operational value of the detector head is lower than its normal range, a trouble condition will be generated.

WARNING: If the operational value of the detector head is higher than 30% during 7 consecutive days, this could be an indication that the detector is contaminated by dust and requires servicing. Investigate any changes in the environment which could explain the higher operational value. If it has been determined that the detector is contaminated, please note that normal detector operation cannot be guaranteed – contact your local supplier for more information and to arrange servicing. Also take precautions to avoid or limit any future contamination.

Cleaning the detector

The exterior of the detector should be cleaned as necessary. Clean the detector with a damp (not wet) cloth.

Caution: Do not use solvents to clean the detector. Use of solvents may cause damage to the detector.

Replacing the dust separator (filter) cartridge

The only part that may require field replacement during servicing is the dust separator (filter) cartridge.

After replacing the filter, the detector must be put into FastLearn mode.

As dust contained in the dust separators may expose maintenance personnel to a “Nuisance Dust” hazard as defined by the Control of Substances Hazardous to Health (COSHH), it is strongly recommended that suitable masks and protective clothing be worn when changing filters.

Note: Used dust separator cartridges are not intended for reuse and should be discarded.

To replace the cartridge:

1. Open the unit’s front cover and locate the dust separator (filter) handle at the bottom right of the detector.
2. Remove the black end piece from the filter cartridge and dispose of the cartridge.
3. Fit the new cartridge into the plastic end piece and slide the entire assembly into the detector, using the handle. The cartridge should be fitted with the legend “IN” towards the front of the detector.
4. Note: If the cartridge is inserted with the wrong orientation, the detector will not register its presence and the Separator change message will remain on the display.
5. When the replacement cartridge is in place, the detector will automatically start a FastLearn routine.
6. Place the front cover back onto the detector.

Figure 29 on page 70 shows how the dust separator (filter) cartridge is replaced. Make sure to push the cartridge fully home, or the detector will fail to register its presence, and will continue to indicate Separator change.

Figure 29: Replacing the dust separator (filter) cartridge

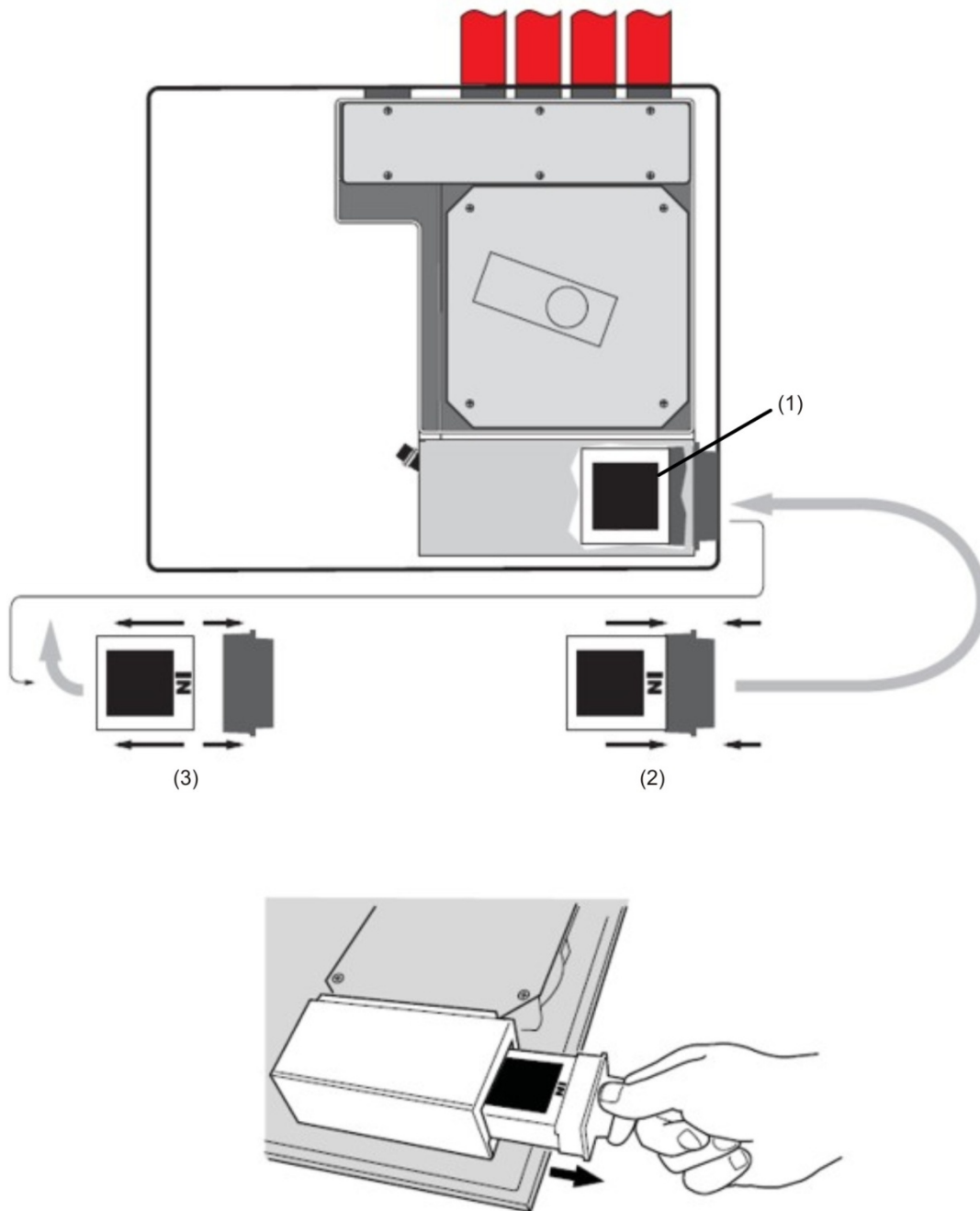

- (1) Filter
- (2) New filter
- (3) Old filter

Appendix A

External communications

Summary

This chapter provides information on other supported external communication methods, supported by BMS variant of the command module. The legend “BMS CM only” means that the function only applies to the BMS variant of the command module, and is not supported by the non BMS Command Module.

Content

BMS protocols on the detector command module	72
Paging from the command module	74
Configuring the software	74

BMS protocols on the detector command module

The legend “BMS CM only” means that the function only applies to the BMS variant of the command module, and is not supported by the non BMS command module.

The command module of the detector has a second RS-232 port that can be used to send messages to a pager or compatible GSM phone using a modem, or to enable connection to a Building Management System (BMS). This comprises the terminals “RS 232 Tx” (transmit), “RS 232 Rx” (receive), and “GND” on the green terminal block inside the unit.

The set-up of the command module uses three functions:

- BMS protocol
- Page on fault
- Page on alarm

When either Page on fault or Page on alarm is enabled, the second serial port is reserved exclusively for paging purposes by setting BMS protocol to 0 (TAP paging).

The programmable function “BMS protocol” sets the communications format that is used by the second serial port to communicate with the BMS. Setting BMS protocol to anything other than 0 (Tap paging) will disable functions Page on fault and Page on alarm if they are enabled.

Table 9: BMS protocols

Protocol number	Protocol
0	TAP paging (default)
1	Output only. Events are sent in the same ASCII text format as the internal event long display. This may be used to drive a serial printer if required.
2	BACnet ANSI/ASHRAE standard 135-1995
3	MODBUS

Text output support (protocol 1) BMS CM only

Text is output at 9600 baud, 8 bit with no parity. When an event occurs, the event is printed in the following format:

Device “command module” or “Detector n”
 Event “Alarm”
 Time date 10:32 21/03/2001

BACNET support (protocol 2) BMS CM only

The command module models the attached detectors as analog value object types instances 2 to 128. The command module status is stored as analog value instance 1. The Present_Value property of the analog objects can have one of the values shown in Table 10.

MODBUS support (protocol 3) BMS CM only

Refer to the MODBUS Application Protocol standard specification.

Table 10: Values of Present_Value property

Value	Description
0	Disabled
2	Fault
32	Normal
48	Pre-Alarm
64	Alarm
128	Alarm 2

The Device object and the Analog Input objects support the properties shown in Table 11.

Table 11: Device object and Analog Input object properties

Device object	Analog Input objects
Object_Identifier	Object_Identifier
Object_Name	Object_Name
Object_Type	Object_Type
System_Status	Present_Value
Vendor_Name	Status_Flags
Vendor_Identifier	Event_Stater
Model_Name	Out_Of_Service
Firmware_Revision	Units
Application_Software_Version	
Protocol_Version	
Protocol_Conformance_Class	

Device object	Analog Input objects
Protocol_Services_Supported	
Protocol_Object_Types_Supported	
Max_APDU_Length_Accepted	
Segmentation_Supported	
APDU_Timeout	
Number_Of_APDU_Retries	

For additional information on BACnet implementation, contact Technical Support.

Paging from the command module

The detector command module has the ability to send text messages to alphanumeric pagers or SMS messages to some mobile phones.

In order to send messages to a pager or similar device, a modem must be plugged into the RS-232TX and RS-232RX terminals of the command module using a suitable cable.

The pager or SMS-capable phone call centers must support the TAP protocol.

Contact your pager provider to check whether they provide access with the TAP protocol.

Configuring the software

No manual configuration of the modem is required, as the command module configures the modem automatically on dialing.

The command module has three entries used to send messages. The functions are located in Setup menu>Pager.

They are described below:

- Call Centre: The phone number the modem dials up to send a message.
- Password: An optional password used to access the system.
- Pager: The number of the actual pager. This number will be detailed in the pager or SMS phone documentation.

Glossary

Abbreviation	Description
°C	Degrees Centigrade
°F	Degrees Fahrenheit
A	Ampere
AC	Alternating current
ADA	Americans with Disabilities Act
AH	Ampere hour
AHJ	Authority having jurisdiction
ARC	Automatic release circuit
ASD	Aspirating Smoke Detector
AWG	American wire gauge
CSFM	California State Fire Marshal
DACT	Digital alarm comm. transmitter
DC	Direct current
DET	Detector
EOLD	End of line device
EOLR	End of line resistor
FM	Factory Mutual
FSD	Full scale deflection
ft.	Feet
HSSD	High sensitivity smoke detector
Hz	Hertz (frequency)
in.	Inches
LCD	Liquid crystal display
LED	Light emitting diode
MEA	Materials and Equipment Acceptance Division of the City of New York
NAC	Notification appliance circuit
N.C.	Normally closed
NEC	National Electrical Code

Glossary

NFPA	National Fire Protection Association
N.O.	Normally open
NYC	New York City
PCB	Printed circuit board
pF	Pico farads
P/N	Part number
PSU	Power supply unit
RAM	Random access memory
SLC	Signaling line circuit
TB	Terminal block
UL/ULI	Underwriters Laboratories, Inc.
V	Volts
VAC	Volts AC
VDC	Volts DC
VRMS	Volts root mean square

Index

A

Acclimation period, 59

B

BMS protocols on the detector command module, 72

C

Configuring the software, 74

Connecting a Command Module to an addressable fire pane, 32

Connecting a detector network to a command module, 31

Connecting a single detector to an addressable fire panel, 34

Connecting to a PC, 34

Connections

Command module terminal block connections, 24

Connecting power cables, 26

Detector terminal block connections, 22

Power supply connections, 27

D

Demonstration mode, 28

Detector address

Setting the detector address, 29

F

Fault tolerant detector loop configuration, 31

I

Installation, 15

Electrical installation, 21

Mechanical installation, 18

Interfacing with fire alarm panels, 29

M

Maintenance procedures, 67

N

Non-fault tolerant serial configuration, 31

P

Paging from the command module, 74

Programming

detector functions, 40

Main menu, 39

Navigating, 40

programming mode/installer access code, 38

S

Sampling pipe design, 16

Software applications, 2

Specifications, 3

Stand-alone command module/command module detector, 7

Standard and command module detector controls and indicators, 11

Standard detector, 5

Standard detector interior view, 8

T

Transport time verification, 60

Troubleshooting

detector, 62

error messages, 64

