

Confidential

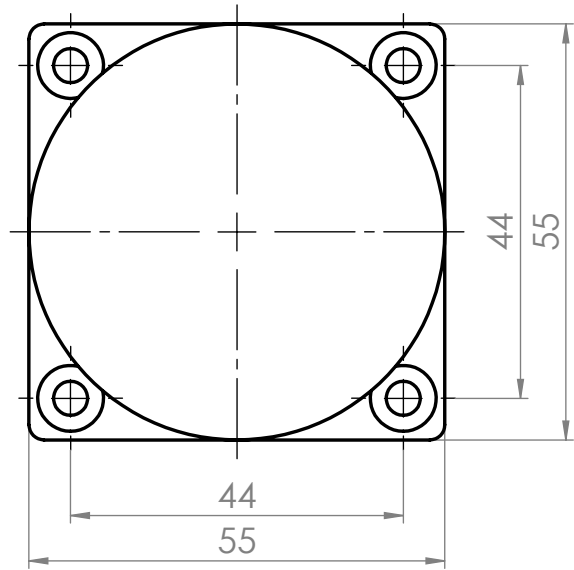

Projektionsmethode PROJECTION		ISO 128 1 (E)		Werkstückkanten WORK PIECE EDGES ISO 13715		Nennmassbereich / NOMINAL SIZE RANGE 0,2...0,5 mm	
				Allgemeintoleranz GENERAL TOLERANCE		Längenmasse LENGTH DIMENSION ± 0,05 mm	
				Oberfläche SURFACE ISO 1302 Reihe 3		Radien, Fasen RADIA, CHAMFERS ± 0,1 mm	
				Datum		Maßstab / SCALE 1: 1	
				Name		Art.Nr. / MAT.-NO.	
				Benennung / DESCRIPTION		Werkstoff, Ausgangsteil / MATERIAL, INITIAL PART	
				Anker, kpl.			
				Armature, complete			
				Zeichnungsnummer / DRAWING NO.		Blatt / PAGE	
				GT050R006-200		1	
				Ers. f. / REPL. Logocad 07.12.2005 Rev.f		1 Bl. / OF	
				Format / SIZE A4		SolidWorks	

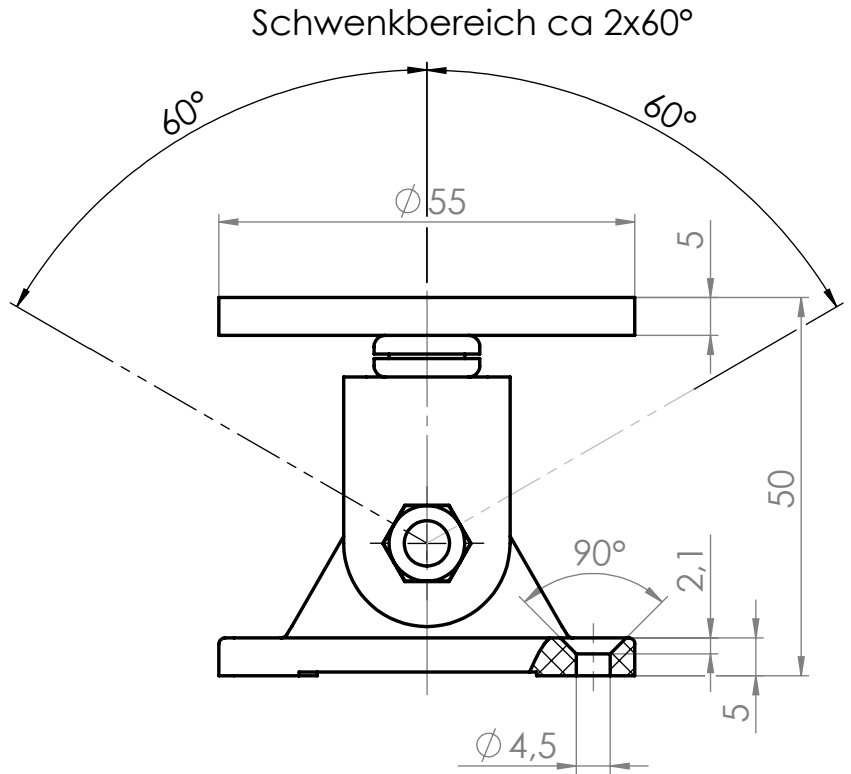
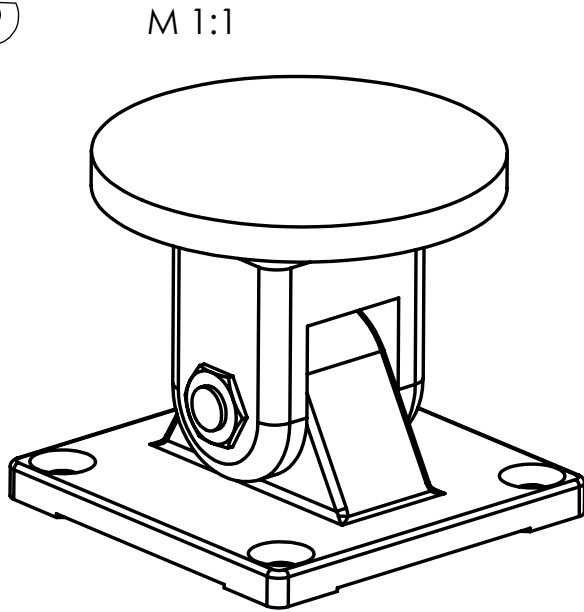