

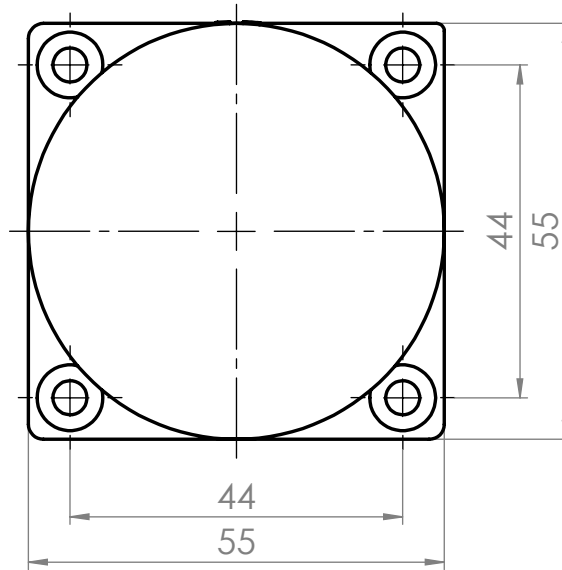

Confidential

M 1:1

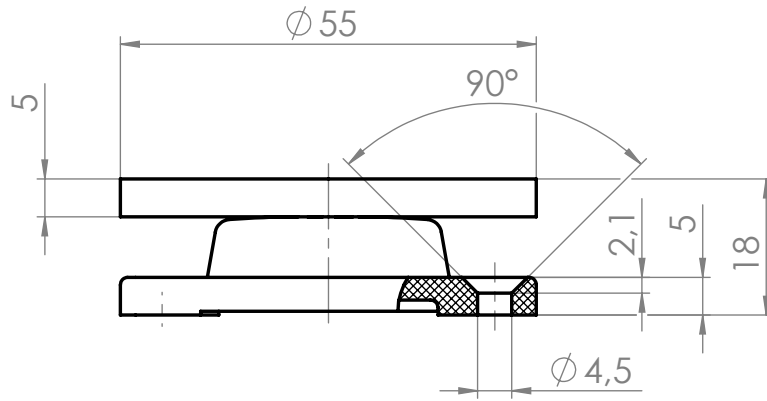
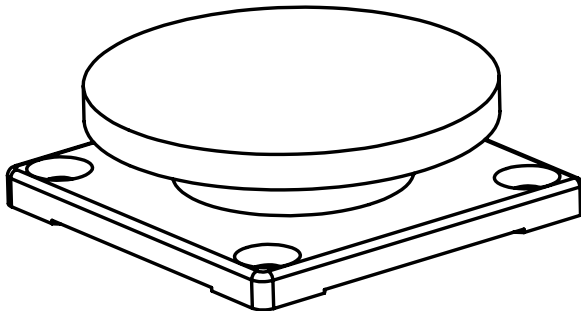

Projektionsmethode PROJECTION		 ISO 128 1 (E)		Werkstückkanten WORK PIECE EDGES ISO 13715		Nennmassbereich / NOMINAL SIZE RANGE 0,2...0,5 mm					
				Allgemeintoleranz GENERAL TOLERANCE		Oberfläche SURFACE		Längenmasse LENGTH DIMENSION	± 0,05 mm	Radien, Fasen RADIA, CHAMFERS	± 0,1 mm
				ISO 1302 Reihe 3		Maßstab / SCALE		1:1		Art.Nr. / MAT.-NO.	
						Werkstoff, Ausgangsteil / MATERIAL, INITIAL PART		Benennung / DESCRIPTION			
				Datum		Name		Anker, kpl.			
				Bearb. DRAWN		13.10.11		hafi		Armature, complete	
				Gepr. CHECK.		15.12.11		jaes		Zeichnungsnummer / DRAWING NO.	
										Blatt / PAGE	
a		ern		ÄA.Nr.1393		13.10.11		hafi		1	
Zust. REV.1.		Anz. Qty.		Änderung REV. DESC.		Datum DATE		Name NAME		1 Bl. / OF	
										Ers. f. / REPL. Logocad 07.12.1999 Rev.f	
										Format / SIZE A4	
										SolidWorks	

