

DC418 Magnetic Contact Operation and Installation Manual

Figure 1

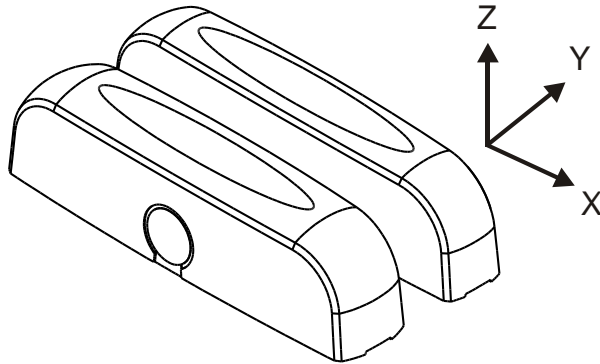

Figure 2

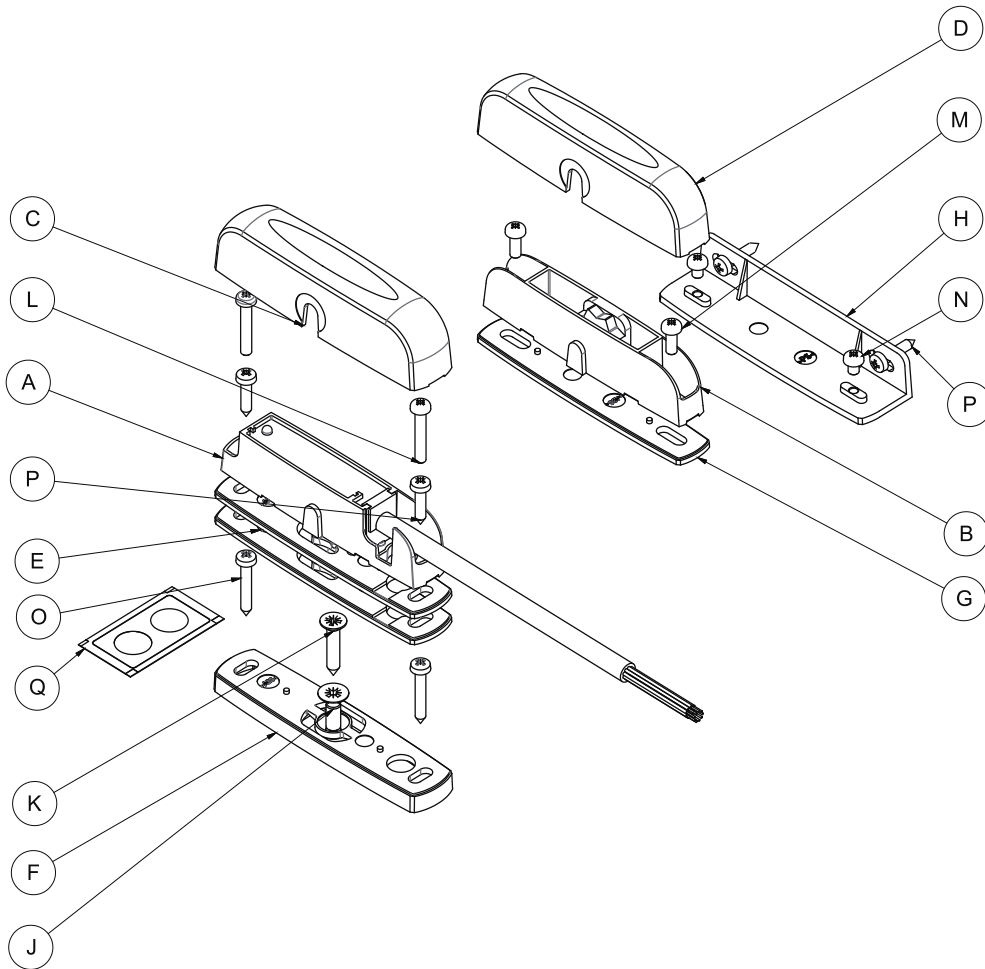

Figure 3

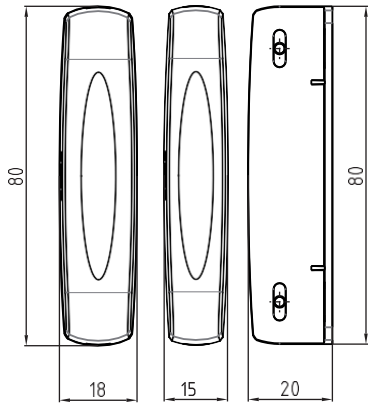

Figure 4

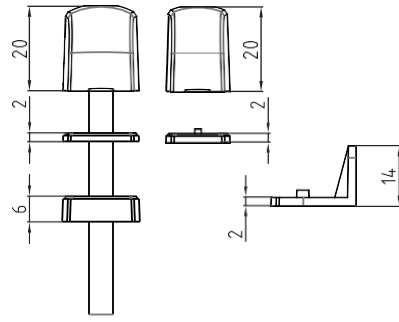

Figure 5

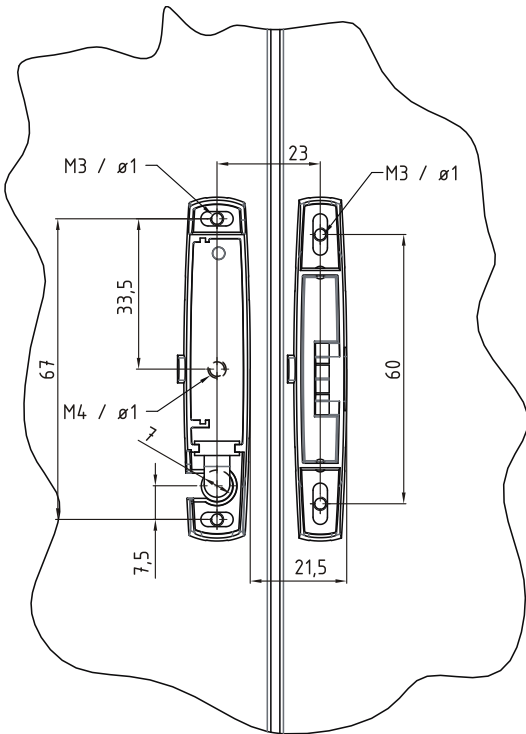

Figure 6

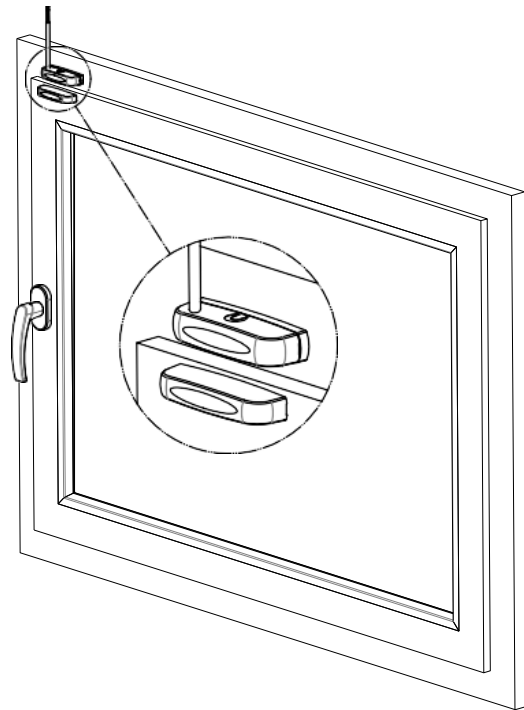

Figure 7

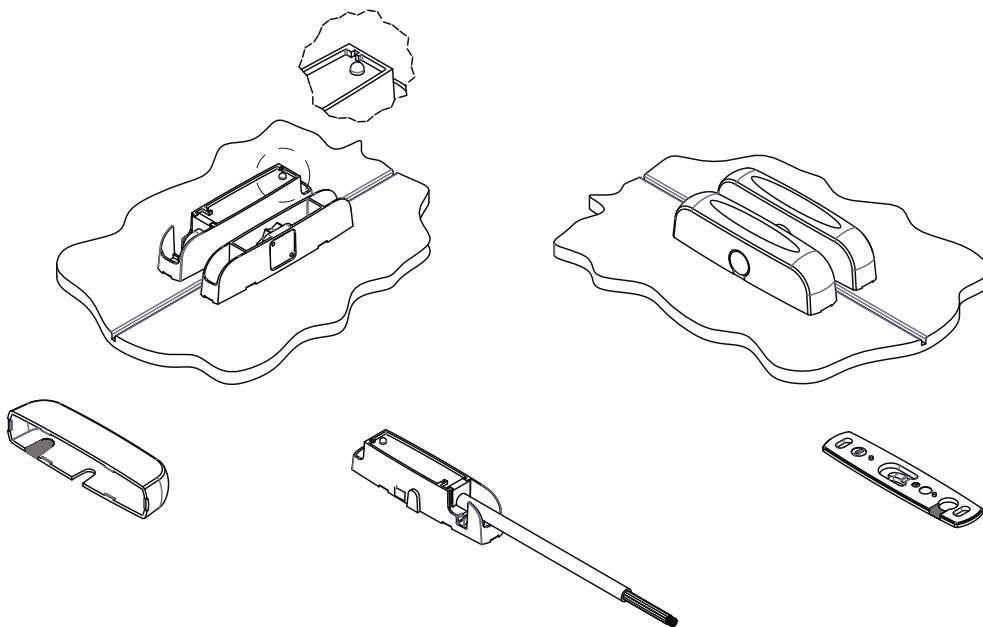

Figure 8

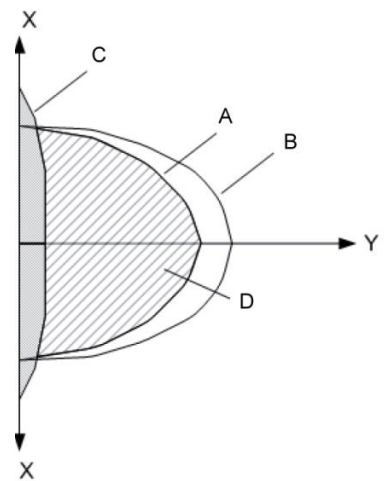

Figure 9

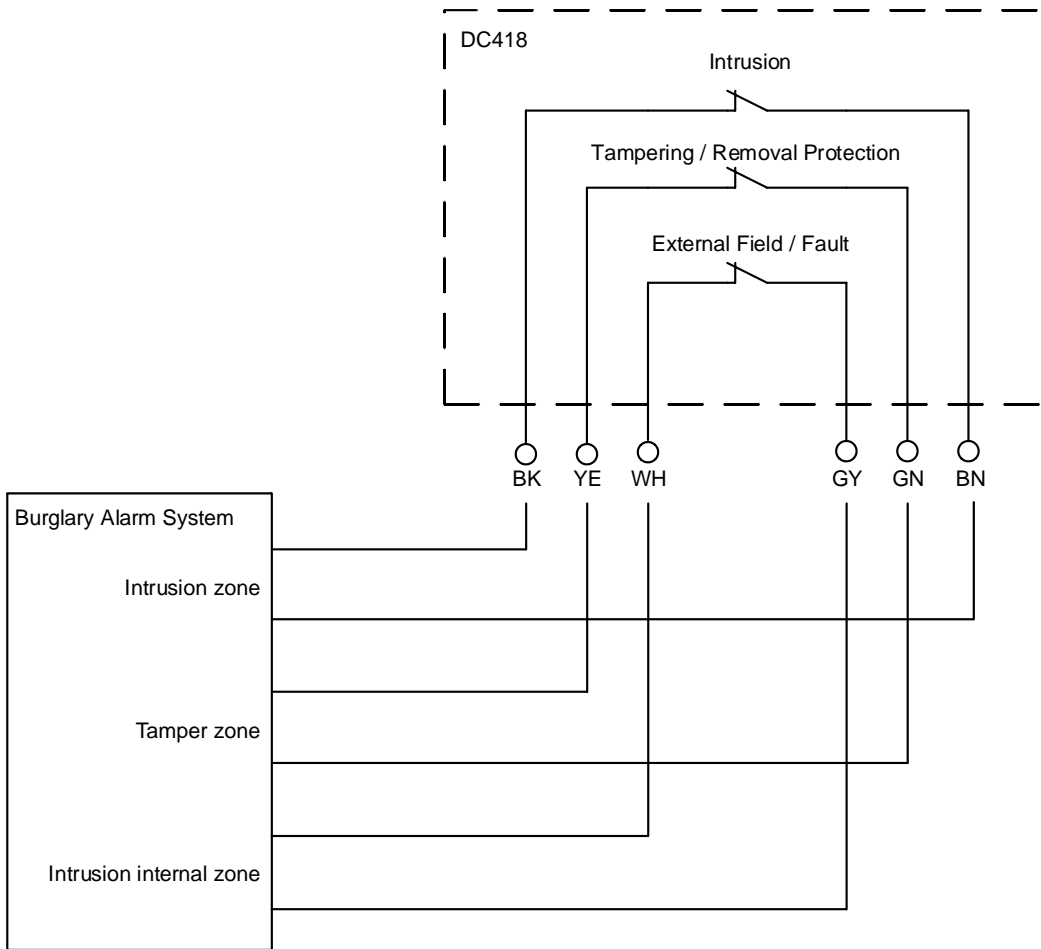
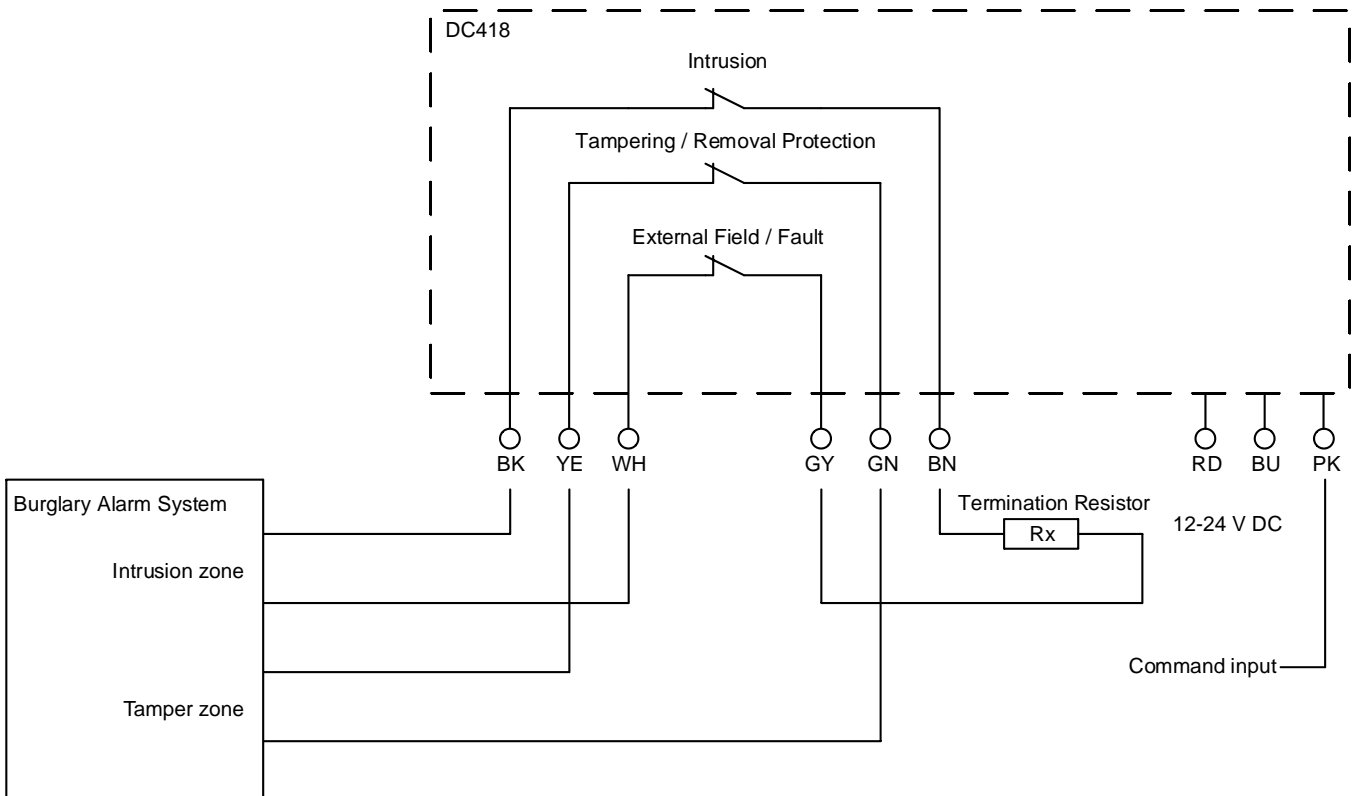

Figure 10



Description

Thanks to its certification according to EN 50131-2-6:2008 grade 4, the magnetic detector DC418 allows for contact-free opening monitoring of doors and windows in accordance with the highest security requirement specifications.

Compared to other high-security magnetic detectors, this product also has enhanced external field monitoring, which can be used to detect an abnormally large difference between the code that was applied and the code that was taught in.

The ability to teach-in this detector to one of eight different magnet variants at the installation location provides for a higher level of security and allows the system to remain relatively flexible with respect to tolerances. The code is assigned at the installation location and is not already defined for the detector at the factory. If a magnetic component is lost or damaged, you can simply replace it with a new one and then teach-in the detector to the new component.

According to the EN the connection wires are suitable for the connection of an alarm wire loop. The maximum number of detectors that can be connected in series for the evaluation is based on the maximum permitted values of the relevant alarm system.

The electronic switches, are potential-free relating to direct current from the rest of the circuit, and are closed when not in use.

The following table provides an overview of the behaviour of the out- puts under various conditions.

Table 1: Generation of signals

Signals	Intrusion	Tamper	Fault
Magnetic field is too weak	1		
Magnetic field is within the tolerance based on its orientation and intensity			
Magnetic field is too strong	1		1
Magnetic field is within the tolerance based on its intensity, but outside of the tolerance based on its orientation	1		1
Detector is removed from the installation surface		1	
Voltage is below the minimum voltage level	1		1
Command mode is active			1

Legend: 1 – Alarm was triggered

If none of the conditions is true, no alarm signal will be generated.

Installation

Scope of delivery

All of the components that are included in the scope of delivery are shown in Figure 2. Please check whether you have all components and tools before you begin with the installation.

Item	No	Description
A	1	Magnetic detector AMK 100
B	1	Magnet AMK 100
C	1	Detector Cover
D	1	Magnet Cover
E	2	Spacer Disk

Item	No	Description
F	1	Spacer Disk (Large)
G	1	Spacer Disk (Magnet)
H	1	Mounting Bracket
J	1	Countersunk Screw M4x12
K	1	Countersunk Sheet-Metal Screw 3,5x19
L	2	Dome Head Screw M3x18
M	2	Dome Head Screw M3x8
N	2	Dome Head Screw M3x4
O	2	Dome Head Sheet-Metal Screw 2,9x19
P	4	Dome Head Sheet-Metal Screw 2,9x13
Q	1	Double Sticker

Positioning

For positioning, take note of Figure 5 and the following instructions. The orientation from the magnetic housing to the detector housing is predefined and must conform to the illustration.

Install the detector and magnet by screwing them in at the installation location. Each of the components is provided with two drill holes on the side of the housing for this purpose.

When mounting on ferromagnetic materials, the detector and magnet must be mounted on the side of the frame towards which it is opened.

Note: A minimum clearance of 2 mm to ferromagnetic materials has to be ensured by means of the provided spacers.

To ensure reliable detection of tampering, an installation gap of between 5 and 15 mm must be maintained between the magnet and the detector. Also be sure not to exceed the maximum installation offset of 1.5 mm on the sides.

This refers to the offset on all sides in the entire level, parallel to the opposite surfaces. You can use the included spacers to compensate for differing installation levels of the detector and magnet.

After the detector has been taught-in to the magnet, the relative position of these two components (with respect to one another) must not be changed by more than 1.5 mm (tolerance). Possible reasons for such a difference include strong temperature dependencies or readjustment. If this value is exceeded, the detector must be retaught to the magnets. When you do this, make sure that the required installation offsets are still maintained.

If the offset is within 1.5 mm after you have taught-in the detector, the maximum gap that is created between the two components may exceed the original installation gap.

Finishing the installation

Figure 7 provides a detailed view of which elements of the detector are relevant for finishing installation.

If the cable is to be routed out of the side of the housing, the thinner housing section on the inside must be disengaged and the cable must be moved accordingly, before you screw in the detector. Do not place the housing cover on the detector until you have finished the teach-in procedure (see "Configuration" section); otherwise, the LEDs that are needed for the teach-in procedure will no longer be visible.

After you put the housing cover on, seal both detector components with the supplied stickers.

When connecting the wires, make sure that the command wires are either insulated or connected to a fixed potential, to prevent undesired execution of commands. Also make sure that solely the installation contractor has access to the command wire. Thus it must not be laid to the alarm control unit.

The detector is encapsulated so that it meets protection class IP 67, in accordance with IEC 529. The switch for removal protection also has the same protection class.

Configuration

Note: To configure the detector, it has to be connected to a power supply.

Basics – command types

The grade 4 magnetic detector has three different commands:

- Learn-in the unit to the environment
- Learn -in the unit to the magnet
- Reset all values

All commands are triggered by a brief connection of the command wire to the zero potential (“contact ground”).

Figure 11: Overview of learning phases

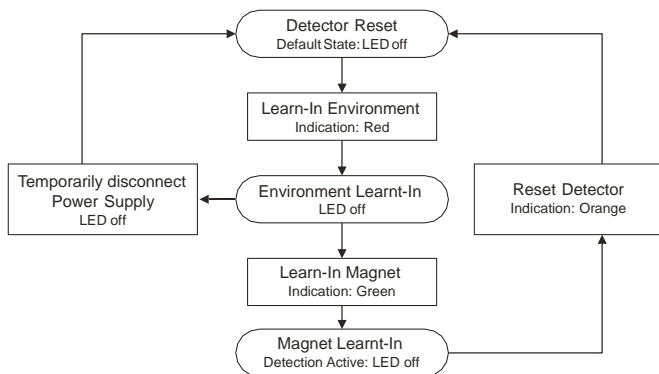

Standard learn-in procedure

Both learn-in commands must be executed to learn-in the detector.

Learning-in the unit to the installation environment

Before learning the unit to the environment, make sure that there are no devices or objects in the immediate vicinity of the magnetic switch which could create a strong magnetic field and disturb the detector in performing its functions. The magnet that belongs to the detector may also not be located within the immediate vicinity when you learn-in the detector to the environment.

Note: You can only learn-in the detector to the environment when it is in the “Detector Reset” state. To reset the detector, proceed as described in the “Resetting the detector” section.

To learn-in the unit to the installation environment:

1. Contact the command wire to ground to activate the learn-in procedure for the environment.

2. The LED lights up red for several seconds to indicate that the “Learn-in Environment” command was selected.
3. The LED then starts to flash red for several seconds. Contact the command wire to ground again to confirm the command. If you do not want to execute the command, let the confirmation time elapse.
4. If you confirm the command in time, the LED stops flashing. The detector switches to the “Environment Learnt-In” state, in which you can learn-in the unit to the magnet.

Learning-in the unit to the magnet

You can only learn-in the detector to the magnet when it is in the “Environment Learnt-In” state. To learn-in the detector to the environment, proceed as described in the “Learning-in the unit to the environment” section.

If an error occurred during the learn-in process of the unit to the environment, the detector can be reset without having to first learn-in the unit to the magnet.

This can be achieved by a brief disconnection of the power-supply. Afterwards, proceed according to the “Learning-in the unit to the installation environment” section.

Note: The magnet must already be correctly installed at this time. To improve visibility of the LED while selecting this command, you can hold the magnet outside of its closed position (open window/ door). In this case, be ready to immediately return the magnet to its closed position when required to do so.

To learn-in the unit to the magnet:

1. Contact the command wire to ground to activate the learn-in procedure for the magnet.
2. The LED lights up green for several seconds to indicate that the “Learn-In Magnet” command was selected.
3. The LED then starts to flash green for several seconds. Contact the command wire to ground again to confirm the command. If you do not want to execute the command, let the confirmation time elapse.
4. If you confirm the command in time, the LED flashes more quickly. Now return the magnet to its closed position (if it is not already in that position). If the requirements are met, the detector switches to the “Magnet Learnt-In” state, in which the monitoring of the magnet position and the signal outputs are activated.
5. A red lamp indicates that the magnet was incorrectly positioned or that the magnetic field is too small due to other reasons. In this case, the detector remains in the “Environment Learnt-In” state, and the unit must be learnt-in to the magnet again.

Resetting the detector

A detector reset is required when you need to update the previously learnt-in data or adjust the detector to a new magnet or installation situation.

Note: Once you reset the detector, all changes you made are lost.

1. Contact the command wire to ground to activate the reset procedure.
2. The LED lights up orange for several seconds to indicate that the “Reset Detector” command was selected.

- The LED then starts to flash orange for several seconds. Contact the command wire to ground again to confirm the command. If you do not want to execute the command, let the confirmation time elapse.
- If you confirm the command in time, the LED stops flashing. The detector discards all changes and switches to the "Detector Reset" state, in which you can learn-in the unit to the environment.

Wiring configuration for EN version

Wire(s)	Type	Assignment
Red (RD)	Supply	Supply voltage (+)
Blue (BU)	Supply	Ground (-)
Pink (PK)	Input	Command input
Black (BK), brown (BN)	Output	Intrusion
Yellow (YE), green (GN)	Output	Tampering (removal protection)
White (WH), grey (GY)	Output	Fault (external field)

Note: See Figures 9 and 10.

Distances

Mounted on non-ferromagnetic material

Approach distance	15 mm ±3 mm
Break distance	18 mm ±3 mm
Fault trigger distance	-3 mm ±1 mm

Mounted on ferromagnetic material

Approach distance	30 mm ±20%
Break distance	27 mm ±30%
Fault trigger distance	29 mm ±30%

See Figure 8.

The values refer to the Y-distance relative to the learning position. Values along the Z-axis may differ. If required they are to be determined separately.

- The distances may vary depending on the installation situation, the magnetic code and the learning distance. Before the device is brought into service, they are to be verified.

Specifications

Operating voltage	12 to 24 V DC
Power consumption (monitoring mode)	Approx. 5 mA (typical)
Power consumption (learn-in mode, LED)	max. 13 mA
Permitted installation gap between magnet and detector	5 to 12 mm
Installation offset on the sides (revolving)	max. 1.5 mm
Clearance from metal components	min. 2 mm
Permitted tolerance after learn-in (radial)	max. 1.5 mm
Signal output	Electronic switch
Transfer resistance (closed)	approx. 7 Ω (typical)
Transfer resistance (open)	≥10 MΩ
Electrical isolation between input and output	min. 30 V
Permitted output current	max. 50 mA
Permitted output voltage	max. 30 V
Measurement speed	approx. 100 ms
Connection cable	LIYY 9x0.14 mm ² copper tin-plated

Cable conductors	See Table 1
Cable diameter	Ø5.8 mm
Cable length	Up to 10 m
Contact dimensions	80 x 18 x 20 mm
Magnet dimensions	80 x 15 x 20 mm
Temperature range	-40 to +70°C

Regulatory information

Manufacturer	PLACED ON THE MARKET BY: Carrier Fire & Security Americas Corporation Inc. 13995 Pasteur Blvd Palm Beach Gardens, FL 33418, USA AUTHORIZED EU REPRESENTATIVE: Carrier Fire & Security B.V. Kelvinstraat 7, 6003 DH Weert, Netherlands
--------------	---

Product warnings and disclaimers

THESE PRODUCTS ARE INTENDED FOR SALE TO AND INSTALLATION BY QUALIFIED PROFESSIONALS. CARRIER FIRE & SECURITY CANNOT PROVIDE ANY ASSURANCE THAT ANY PERSON OR ENTITY BUYING ITS PRODUCTS, INCLUDING ANY "AUTHORIZED DEALER" OR "AUTHORIZED RESELLER", IS PROPERLY TRAINED OR EXPERIENCED TO CORRECTLY INSTALL FIRE AND SECURITY RELATED PRODUCTS.



For more information on warranty disclaimers and product safety information, please check <https://firesecurityproducts.com/policy/product-warning/> or scan the QR code.

Protection class	IP67 EN III/A
------------------	---------------



Certification	Grade 4, EN-ST-000222
---------------	-----------------------

European Union directives

Carrier Fire & Security hereby declares that this device is in compliance with the applicable requirements and provisions of the Directive 2014/30/EU and/or 2014/35/EU. For more information see firesecurityproducts.com or www.aritech.com

REACH

Product may contain substances that are also Candidate List substances in a concentration above 0.1% w/w, per the most recently published Candidate List found at ECHA Web site.

Safe use information can be found at <https://firesecurityproducts.com/en/content/intrusion-intro>



2012/19/EU (WEEE directive): Products marked with this symbol cannot be disposed of as unsorted municipal waste in the European Union. For proper recycling, return this product to your local supplier upon the purchase of equivalent new equipment, or dispose of it at designated collection points. For more information see: www.recyclethis.info.

Contact information

firesecurityproducts.com or www.aritech.com