

# AAECU-EOL

## AlarmLine II Analogue EN LHD Replacement Part – EOL module

### General

---

The AAECU-EOL is a replacement End-Of-Line unit for use with the AlarmLine II Analogue EN Liner Heat Detection (LHD) cable control unit. The AAECU control unit is supplied with an AAECU-EOL included, but in case the unit is lost or damaged then the AAECU-EOL can be supplied separately.



### Details

---

- VdS EN54-22:2015/prA1:2007

# AAECU-EOL

## AlarmLine II Analogue EN LHD Replacement Part – EOL module

### Technical specifications

#### Physical

Physical dimensions	100 x 35 x 60 mm (4" x 1 3/8" x 2 3/8") (W x H x D)
Net weight	115 g
Mounting type	Surface mount
Material (body)	Aluminium

#### Environmental

Operating temperature	-40 to +125°C
Relative humidity	0 to 99% ambient temperature -40 to +40°C / 0 to 75% ambient temperature greater than +40°C
IP rating	IP65

#### Regulatory

Certification	CE, EN54-22, VdS
---------------	------------------

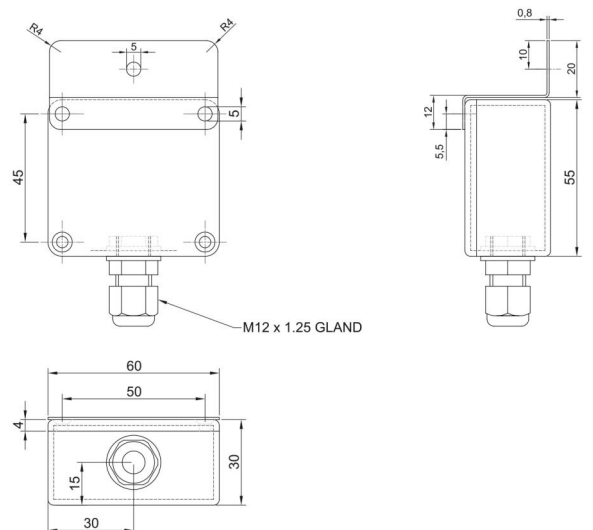

Figure 3. AlarmLine II Analogue EN EOL unit Dimensional Drawing



As a company of innovation, Carrier Fire & Security reserves the right to change product specifications without notice. For the latest product specifications, visit [firesecurityproducts.com](http://firesecurityproducts.com) online or contact your sales representative.

Last updated on 13 September 2024 - 13:13